

# 2

## SINGLE-GENE INHERITANCE

### WORKING WITH THE FIGURES

1. In the left-hand part of Figure 2-4, the red arrows show selfing as pollination within single flowers of one  $F_1$  plant. Would the same  $F_2$  results be produced by cross-pollinating two different  $F_1$  plants?

Answer: No, the results would be different. While self-pollination produces 3:1 ratio of yellow versus green phenotype, cross-pollination would result in 1:1 ratio in the  $F_2$ . This is because  $F_1$  yellow are heterozygous, while green are homozygous genotypes.

2. In the right-hand part of Figure 2-4, in the plant showing an 11:11 ratio, do you think it would be possible to find a pod with all yellow peas? All green? Explain.

Answer: Yes, it is possible to find complete pods with only yellow peas or only green peas from the cross shown, though it would be highly unlikely. It would have the same likelihood of occurring as flipping a coin and getting heads six times in a row.

3. In Table 2-1, state the recessive phenotype in each of the seven cases.

Answer: wrinkled seeds; green seeds; white petals; pinched pods; yellow pods; terminal flowers; short stems

4. Considering Figure 2-8, is the sequence “pairing → replication → segregation → segregation” a good shorthand description of meiosis?

Answer: No, it should say either “pairing, recombination, segregation, segregation” or “replication, pairing, segregation, segregation.”

5. Point to all cases of bivalents, dyads, and tetrads in Figure 2-11.

Answer: Replicate sister chromosomes or dyads are at any chromatid after the replication (S phase). A pair of synapsed dyads is called a bivalent, and it would represent two dyads together (sister

chromatids on the right), while the four chromatids that make up a bivalent are called a tetrad, and they would be the entire square (with same or different alleles on the bivalents).

6. In Figure 2-11, assume (as in corn plants) that allele  $A$  encodes an allele that produces starch in pollen and allele  $a$  does not. Iodine solution stains starch black. How would you demonstrate Mendel's first law directly with such a system?

Answer: One would use this iodine dye to color the starch-producing corn pollen. Since pollen is a plant gametophyte generation (haploid), it will be produced by meiosis. Mendel's first law predicts segregation of alleles into gametes; therefore, we would expect 1:1 ratio of starch-producing ( $A$ ) versus non-starch-producing ( $a$ ) pollen grains, from a heterozygous ( $A/a$ ) parent/male flower. It would be easy to color the pollen and count the observed ratio.

7. Considering Figure 2-13, if you had a homozygous double mutant  $m3/m3\ m5/m5$ , would you expect it to be mutant in phenotype? (**Note:** This line would have two mutant sites in the same coding sequence.)

Answer: Yes, this double mutant  $m3/m3\ m5/m5$  would be a null mutation because  $m3$  mutation changes the exon sequence. Because the  $m5$  mutation is silent, the homozygous double mutant  $m3/m3\ m5/m5$  would have the same mutant phenotype as an  $m3/m3$  double mutant.

8. In which of the stages of the *Drosophila* life cycle (represented in the box on page 56) would you find the products of meiosis?

Answer: Meiosis happens in adult ovaries and testes to produce gametes (sperm and unfertilized egg). Thus, the adult fly in the diagram would generate gametes and participate in mating, and the female would then lay the fertilized diploid embryos (eggs).

9. If you assume Figure 2-15 also applies to mice and you irradiate male sperm with X rays (known to inactivate genes via mutation), what phenotype would you look for in progeny in order to find cases of individuals with an inactivated *SRY* gene?

Answer: Individuals with an inactivated *SRY* gene would be phenotypically female with an XY sex chromosomal makeup. These individuals are often called "sex reversed" and are always sterile. Hence, we would look for flies that are phenotypically female, but sterile.

10. In Figure 2-17, how does the 3:1 ratio in the bottom-left-hand grid differ from the 3:1 ratios obtained by Mendel?

Answer: It differs because, in Mendel's experiments, we learned about autosomal genes, while in this case, we have a sex-linked gene for eye color.

3:1 ratio means that all females have red eyes ( $X^{+/-}$ ), while half the males have red ( $X^{+}/Y$ ) and half have white ( $X^{w}/Y$ ). Careful sex determination when counting  $F_2$  offspring would point out to a sex-linked trait.

11. In Figure 2-19, assume that the pedigree is for mice, in which any chosen cross can be made. If you bred IV-1 with IV-3, what is the probability that the first baby will show the recessive phenotype?

Answer:  $2/3 \times 2/3 \times 1/4 = 1/9$ , or 0.11

The probability that IV-1 and IV-3 mice are heterozygous is  $2/3$ . This is because both of their parents are known heterozygotes ( $A/a$ ), and since they are the dominant phenotype, they could only be  $A/A$  or  $A/a$ . Now the probability that two heterozygotes have a recessive homozygote offspring is  $1/4$ .

12. Which part of the pedigree in Figure 2-23 in your opinion best demonstrates Mendel's first law?

Answer: Any part of this pedigree demonstrates the law, showing segregation of alleles into gametes. Notice how 50 percent of the children of I-1 and I-2 display the dominant trait, consistent with I-1 contributing either the dominant or the recessive allele to each gamete in equal frequencies (1:1). The middle part of generation II marriage shows a typical testcross (expected 1:1). Neither ratio in the pedigree could be confirmed because of a small sample size in any given family, but allele segregation is obvious.

13. Could the pedigree in Figure 2-31 be explained as an autosomal dominant disorder? Explain.

Answer: Yes, it could in some cases, but in this case we have clues that the pedigree is for a sex-linked dominant trait. First, if fathers have a gene, only daughters would receive it; and second, if mothers have a gene, both sons and daughters would receive it.

## BASIC PROBLEMS

14. Make up a sentence including the words *chromosome*, *genes*, and *genome*.

Answer: The human genome contains an estimated 20,000–25,000 genes located on 23 different chromosomes.

15. Peas (*Pisum sativum*) are diploid and  $2n = 14$ . In *Neurospora*, the haploid fungus,  $n = 7$ . If it were possible to fractionate genomic DNA from both species by using pulsed field electrophoresis, how many distinct DNA bands would be visible in each species?

Answer: PFGE separates DNA molecules by size. When DNA is carefully isolated from *Neurospora* (which has seven different chromosomes), seven bands should be produced using this technique.



21. In a possible future scenario, male fertility drops to zero, but, luckily, scientists develop a way for women to produce babies by virgin birth. Meioocytes are converted directly (without undergoing meiosis) into zygotes, which implant in the usual way. What would be the short-term and long-term effects in such a society?

Answer: In large part, this question is asking: Why sex? Parthenogenesis (the ability to reproduce without fertilization—in essence, cloning) is not common among multicellular organisms. Parthenogenesis occurs in some species of lizards and fishes and several kinds of insects, but it is the only means of reproduction in only a few of these species. In plants, about 400 species can reproduce asexually by a process called apomixis. These plants produce seeds without fertilization. However, the majority of plants and animals reproduce sexually. Sexual reproduction produces a wide variety of different offspring by forming new combinations of traits inherited from both the father and the mother. Despite the numerical advantages of asexual reproduction, most multicellular species that have adopted it as their only method of reproducing have become extinct. However, there is no agreed-upon explanation of why the loss of sexual reproduction usually leads to early extinction, or conversely, why sexual reproduction is associated with evolutionary success. On the other hand, the immediate effects of such a scenario are obvious. All offspring would be genetically identical to their mothers, and males would be extinct within one generation.

22. In what ways does the second division of meiosis differ from mitosis?

Answer: As cells divide mitotically, each chromosome consists of identical sister chromatids that are separated to form genetically identical daughter cells. Although the second division of meiosis appears to be a similar process, the “sister” chromatids are likely to be different. Recombination during earlier meiotic stages has swapped regions of DNA between sister and nonsister chromosomes such that the two daughter cells of this division typically are not genetically identical.

23. Make up mnemonics for remembering the five stages of prophase I of meiosis and the four stages of mitosis.

Answer: The four stages of mitosis are prophase, metaphase, anaphase, and telophase. The first letters, PMAT, can be remembered by a mnemonic such as Playful Mice Analyze Twice.

The five stages of prophase I are leptotene, zygotene, pachytene, diplotene, and diakinesis. The first letters, LZPDD, can be remembered by a mnemonic such as Large Zoos Provide Dangerous Distractions.

24. In an attempt to simplify meiosis for the benefit of students, mad scientists develop a way of preventing premeiotic S phase and making do with having just one division, including pairing, crossing over, and segregation. Would this system work, and would the products of such a system differ from those of the present system?

Answer: Yes, it could work, but certain DNA repair mechanisms (such as postreplication recombination repair) could not be invoked prior to cell division. There would be just two cells as products of this meiosis, rather than four.

25. Theodor Boveri said, “The nucleus doesn’t divide; it is divided.” What was he getting at?

Answer: The nucleus contains the genome and separates it from the cytoplasm. However, during cell division, the nuclear envelope dissociates (breaks down). It is the job of the microtubule-based spindle to actually separate the chromosomes (divide the genetic material) around which nuclei reform during telophase. In this sense, it can be viewed as a passive structure that is divided by the cell’s cytoskeleton.

26. Francis Galton, a geneticist of the pre-Mendelian era, devised the principle that half of our genetic makeup is derived from each parent, one-quarter from each grandparent, one-eighth from each great-grandparent, and so forth. Was he right? Explain.

Answer: Yes, half of our genetic makeup is derived from each parent, each parent’s genetic makeup is derived half from each of their parents, etc. The process is a bit more complex when one considers the recombination of homologous chromosomes in prophase I, as is discussed in later chapters.

27. If children obtain half their genes from one parent and half from the other parent, why aren’t siblings identical?

Answer: Because the “half” inherited is very random, the chances of receiving exactly the same half is vanishingly small. Ignoring recombination and focusing just on which chromosomes are inherited from one parent, there are  $2^{23} = 8,388,608$  possible combinations!

28. State where cells divide mitotically and where they divide meiotically in a fern, a moss, a flowering plant, a pine tree, a mushroom, a frog, a butterfly, and a snail.

Answer:

	<b>Mitosis</b>	<b>Meiosis</b>
fern	sporophyte gametophyte	(sporangium)
moss	sporophyte gametophyte	sporophyte (antheridium and archegonium)
plant	sporophyte gametophyte	sporophyte (anther and ovule)
pine tree	sporophyte gametophyte	sporophyte (pine cone)
mushroom	sporophyte gametophyte	sporophyte (ascus or basidium)
frog	somatic cells	gonads
butterfly	somatic cells	gonads
snail	somatic cells	gonads

29. Human cells normally have 46 chromosomes. For each of the following stages, state the number of nuclear DNA molecules present in a human cell:
- Metaphase of mitosis
  - Metaphase I of meiosis
  - Telophase of mitosis

- d. Telophase I of meiosis
- e. Telophase II of meiosis

Answer: This problem is tricky because the answers depend on how a cell is defined. In general, geneticists consider the transition from one cell to two cells to occur with the onset of anaphase in both mitosis and meiosis, even though cytoplasmic division occurs at a later stage.

- a. 46 chromosomes, each with two chromatids = 92 chromatids
- b. 46 chromosomes, each with two chromatids = 92 chromatids
- c. 46 physically separate chromosomes in each of two about-to-be-formed cells
- d. 23 chromosomes in each of two about-to-be-formed cells, each with two chromatids = 46 chromatids
- e. 23 chromosomes in each of two about-to-be-formed cells

30. Four of the following events are part of both meiosis and mitosis, but only one is meiotic. Which one? (1) chromatid formation, (2) spindle formation, (3) chromosome condensation, (4) chromosome movement to poles, (5) synapsis

Answer: (5) chromosome pairing (synapsis)

31. In corn, the allele  $f'$  causes floury endosperm and the allele  $f''$  causes flinty endosperm. In the cross  $f'/f' \text{♀} \times f''/f'' \text{♂}$ , all the progeny endosperms are floury, but in the reciprocal cross, all the progeny endosperms are flinty. What is a possible explanation? (Check the legend for Figure 2-7.)

Answer: First, examine the crosses and the resulting genotypes of the endosperm:

Female	Male	Polar nuclei	Sperm	Endosperm
$f'/f'$	$f''/f''$	$f'$ and $f'$	$f''/f''$	$f'/f'/f''$ (floury)
$f''/f''$	$f'/f'$	$f''$ and $f''$	$f'/f'$	$f''/f''/f'$ (flinty)

As can be seen, the phenotype of the endosperm correlates to the predominant allele present.

32. What is Mendel's first law?

Answer: Mendel's first law states that alleles segregate into gametes during meiosis. This discovery came from his monohybrid experimental crosses.

33. If you had a fruit fly (*Drosophila melanogaster*) that was of phenotype  $A$ , what test would you make to determine if the fly's genotype was  $A/A$  or  $A/a$ ?

Answer: Do a testcross (cross to  $a/a$ ). If the fly was  $A/A$ , all the progeny will be phenotypically  $A$ ; if the fly was  $A/a$ , half the progeny will be  $A$  and half will be  $a$ .

34. In examining a large sample of yeast colonies on a petri dish, a geneticist finds an abnormal-looking colony that is very small. This small colony was crossed with wild type, and products of meiosis (ascospores) were spread on a plate to produce colonies. In total, there were 188 wild-type (normal-size) colonies and 180 small ones.
- What can be deduced from these results regarding the inheritance of the small-colony phenotype? (Invent genetic symbols.)
  - What would an ascus from this cross look like?

Answer:

- A diploid meiocyte that is heterozygous for one gene (for example,  $s^+/s$ , where  $s$  is the allele that confers the small colony phenotype) will, after replication and segregation, give two meiotic products of genotype  $s^+$  and two of  $s$ . If the random spores of many meiocytes are analyzed, you would expect to find about 50 percent normal-size colonies and 50 percent small colonies if the abnormal phenotype is the result of a mutation in a single gene. Thus, the actual results of 188 normal-size and 180 small-size colonies support the hypothesis that the phenotype is the result of a mutation in a single gene.
- The following represents an ascus with four spores. The important detail is that two of the spores are  $s$  and will generate small colonies, and two are  $s^+$  and will generate normal colonies.

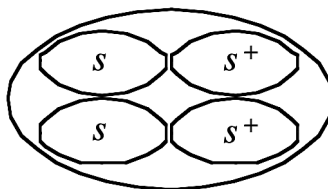

35. Two black guinea pigs were mated and over several years produced 29 black and 9 white offspring. Explain these results, giving the genotypes of parents and progeny.

Answer: The progeny ratio is approximately 3:1, indicating classic heterozygous-by-heterozygous mating. Since black ( $B$ ) is dominant to white ( $b$ ):

Parents:  $B/b \times B/b$

Progeny: 3 black:1 white (1  $B/B$ :2  $B/b$ :1  $b/b$ )

This ratio indicates that black parents were probably heterozygous and that black is dominant over white.

36. In a fungus with four ascospores, a mutant allele  $lys-5$  causes the ascospores bearing that allele to be white, whereas the wild-type allele  $lys-5^+$  results in black ascospores. (Ascospores are the spores that constitute the four products of meiosis.) Draw an ascus from each of the following crosses:
- $lys-5 \times lys-5^+$
  - $lys-5 \times lys-5$
  - $lys-5^+ \times lys-5^+$



Answer:

- a. You expect two *lys-5*<sup>+</sup> (black) spores and two *lys-5* (white) spores.

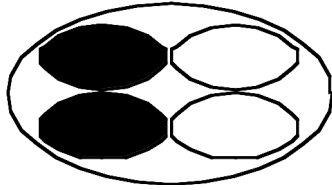

- b. You expect all *lys-5* (white) spores.

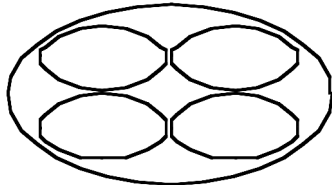

- c. You expect all *lys-5*<sup>+</sup> (black) spores.

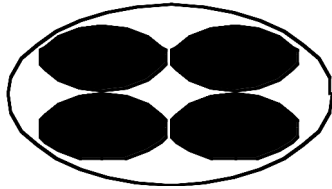

37. For a certain gene in a diploid organism, eight units of protein product are needed for normal function. Each wild-type allele produces five units.
- If a mutation creates a null allele, do you think this allele will be recessive or dominant?
  - What assumptions need to be made to answer part a?

Answer:

- This would be an example of a haploinsufficient gene since one copy of the wild-type allele does not produce enough protein product for normal function. In the absence of knowledge about the biochemistry, we could predict a dominant inheritance pattern, as having one copy of the mutant allele is sufficient to generate the abnormal phenotype.
  - An important assumption would be that having five of eight units of protein product would result in an observable phenotype. It also assumes that the regulation of the single wild-type allele is not affected. Finally, if the mutant allele was leaky rather than null, there might be sufficient protein function when heterozygous with a wild-type allele.
38. A *Neurospora* colony at the edge of a plate seemed to be sparse (low density) in comparison with the other colonies on the plate. This colony was thought to be a possible mutant, so it was removed and crossed with a wild type of the opposite mating type. From this cross, 100 ascospore progeny were obtained. None of the colonies from these ascospores was sparse; all appeared to be normal. What is the simplest explanation of this result? How would you test your explanation? (**Note:** *Neurospora* is haploid.)

Answer: The simplest explanation is that the abnormal phenotype was not due to any genetic change. Perhaps the environment (edge of plate) was less favorable for growth. Since *Neurospora* is haploid and forms ascospores, isolating individual asci from a cross of the possible “mutant” to wild type and individually growing the spores should yield 50 percent wild-type and 50 percent “mutant” colonies. If all spores yield wild-type colonies, the low-density phenotype was not heritable.

39. From a large-scale screen of many plants of *Collinsia grandiflora*, a plant with three cotyledons was discovered (normally, there are two cotyledons). This plant was crossed with a normal, pure-breeding, wild-type plant, and 600 seeds from this cross were planted. There were 298 plants with two cotyledons and 302 with three cotyledons. What can be deduced about the inheritance of three cotyledons? Invent gene symbols as part of your explanation.

Answer: Since half of the  $F_1$  progeny are mutant, it suggests that the mutation that results in three cotyledons is dominant, and the original mutant was heterozygous. Assuming  $C$  = the mutant allele and  $c$  = the wild-type allele, the cross becomes:

P	$C/c \times c/c$
$F_1$	$C/c$ three cotyledons
$c/c$	two cotyledons

40. In the plant *Arabidopsis thaliana*, a geneticist is interested in the development of trichomes (small projections). A large screen turns up two mutant plants (A and B) that have no trichomes, and these mutants seem to be potentially useful in studying trichome development. (If they were determined by single-gene mutations, then finding the normal and abnormal functions of these genes would be instructive.) Each plant is crossed with wild type; in both cases, the next generation ( $F_1$ ) had normal trichomes. When  $F_1$  plants were selfed, the resulting  $F_2$ 's were as follows:

$F_2$  from mutant A: 602 normal; 198 no trichomes  
 $F_2$  from mutant B: 267 normal; 93 no trichomes

- What do these results show? Include proposed genotypes of all plants in your answer.
- Under your explanation to part a, is it possible to confidently predict the  $F_1$  from crossing the original mutant A with the original mutant B?

Answer:

- The data for both crosses suggest that both A and B mutant plants are homozygous for recessive alleles. Both  $F_2$  crosses give 3:1 ratios of normal to mutant progeny. For example, let  $A$  = normal and  $a$  = mutant, then

P	$A/A \times a/a$	
$F_1$	$A/a$	
$F_2$	1 $A/A$	phenotype: normal
	2 $A/a$	phenotype: normal
	1 $a/a$	phenotype: mutant (no trichomes)

- b. No. You do not know if the  $a$  and  $b$  mutations are in the same or different genes. If they are in the same gene, then the  $F_1$  will all be mutant. If they are in different genes, then the  $F_1$  will all be wild type.
41. You have three dice: one red (R), one green (G), and one blue (B). When all three dice are rolled at the same time, calculate the probability of the following outcomes:
- 6 (R), 6 (G), 6 (B)
  - 6 (R), 5 (G), 6 (B)
  - 6 (R), 5 (G), 4 (B)
  - No sixes at all
  - A different number on all dice

Answer: Each die has six sides, so the probability of any one side (number) is  $1/6$ . To get specific red, green, and blue numbers involves “and” statements that are independent. So each independent probability is multiplied together.

- $(1/6)(1/6)(1/6) = (1/6)^3 = 1/216$
- $(1/6)(1/6)(1/6) = (1/6)^3 = 1/216$
- $(1/6)(1/6)(1/6) = (1/6)^3 = 1/216$
- To not roll any sixes is the same as getting anything but sixes:  
 $(1 - 1/6)(1 - 1/6)(1 - 1/6) = (5/6)^3 = 125/216$ .
- The easiest way to approach this problem is to consider each die separately. The first die thrown can be any number. Therefore, the probability for it is 1.  
 The second die can be any number except the number obtained on the first die. Therefore, the probability of not duplicating the first die is  $1 - p(\text{first die duplicated}) = 1 - 1/6 = 5/6$ .  
 The third die can be any number except the numbers obtained on the first two dice. Therefore, the probability is  $1 - p(\text{first two dice duplicated}) = 1 - 2/6 = 2/3$ .  
 Finally, the probability of all different dice is  $(1)(5/6)(2/3) = 10/18 = 5/9$ .

42. In the pedigree below, the black symbols represent individuals with a very rare blood disease.

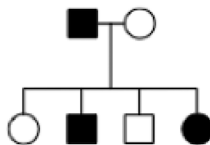

If you had no other information to go on, would you think it more likely that the disease was dominant or recessive? Give your reasons.

Answer: You are told that the disease being followed in this pedigree is very rare. If the allele that results in this disease is recessive, then the father would have to be homozygous and the mother would have to be heterozygous for this allele. On the other hand, if the trait is dominant, then all that is necessary to explain the pedigree is that the father is heterozygous for the allele that causes the disease. This is the better choice, as it is more likely given the rarity of the disease.

43. a. The ability to taste the chemical phenylthiocarbamide is an autosomal dominant phenotype, and the inability to taste it is recessive. If a taster woman with a nontaster father marries a taster man

who had a nontaster daughter in a previous marriage, what is the probability that their first child will be:

- (1) a nontaster girl?
- (2) a taster girl?
- (3) a taster boy?

- b. What is the probability that their first two children will be tasters of either sex?

Answer:

- a. By considering the pedigree (below), you will discover that the cross in question is  $T/t \times T/t$ . Therefore, the probability of being a taster is  $3/4$ , and the probability of being a nontaster is  $1/4$ .

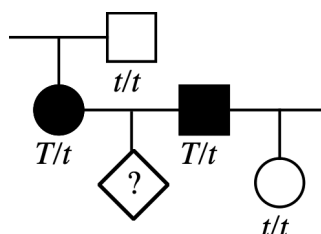

Also, the probability of having a boy equals the probability of having a girl equals  $1/2$ .

$$(1) p(\text{nontaster girl}) = p(\text{nontaster}) \times p(\text{girl}) = 1/4 \times 1/2 = 1/8$$

$$(2) p(\text{taster girl}) = p(\text{taster}) \times p(\text{girl}) = 3/4 \times 1/2 = 3/8$$

$$(3) p(\text{taster boy}) = p(\text{taster}) \times p(\text{boy}) = 3/4 \times 1/2 = 3/8$$

- b.  $p(\text{taster for first two children}) = p(\text{taster for first child}) \times p(\text{taster for second child}) = 3/4 \times 3/4 = 9/16$

44. John and Martha are contemplating having children, but John's brother has galactosemia (an autosomal recessive disease) and Martha's great-grandmother also had galactosemia. Martha has a sister who has three children, none of whom have galactosemia. What is the probability that John and Martha's first child will have galactosemia?

### Unpacking the Problem

1. Can the problem be restated as a pedigree? If so, write one.

Answer: Yes. The pedigree is given below.

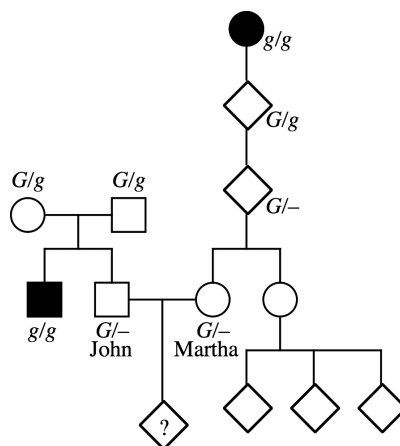

2. Can parts of the problem be restated by using Punnett squares?

Answer: In order to state this problem as a Punnett square, you must first know the genotypes of John and Martha. The genotypes can be determined only through considering the pedigree. Even with the pedigree, however, the genotypes can be stated only as  $G/-$  for both John and Martha.

The probability that John is carrying the allele for galactosemia is  $2/3$ , rather than the  $1/2$  that you might guess. To understand this, recall that John's parents must be heterozygous in order to have a child with the recessive disorder while still being normal themselves (the assumption of normalcy is based on the information given in the problem). John's parents were both  $G/g$ . A Punnett square for their mating would be:

		Father	
		$G$	$g$
Mother	$G$	$G/G$	$G/g$
	$g$	$G/g$	$g/g$

The cross is:

P	$G/g \times G/g$
F <sub>1</sub>	$g/g$ John's brother
	$G/-$ John (either $G/G$ or $G/g$ )

The expected ratio of the F<sub>1</sub> is 1  $G/G$ :2  $G/g$ :1  $g/g$ . Because John does not have galactosemia (an assumption based on the information given in the problem), he can be either  $G/G$  or  $G/g$ , which occurs at a ratio of 1:2. Therefore, his probability of carrying the  $g$  allele is  $2/3$ .

The probability that Martha is carrying the  $g$  allele is based on the following chain of logic. Her great-grandmother had galactosemia, which means that she had to pass the allele to Martha's grandparent. Because the problem states nothing with regard to the grandparent's phenotype, it must be assumed that the grandparent was normal, or  $G/g$ . The probability that the grandparent passed it to Martha's parent is  $1/2$ . Next, the probability that Martha's parent passed the allele to Martha is also  $1/2$ , assuming that the parent actually has it. Therefore, the probability that Martha's parent has the allele and passed it to Martha is  $1/2 \times 1/2$ , or  $1/4$ .

In summary:

John	$p(G/G) = 1/3$
	$p(G/g) = 2/3$
Martha	$p(G/G) = 3/4$
	$p(G/g) = 1/4$

This information does not fit easily into a Punnett square.

3. Can parts of the problem be restated by using branch diagrams?

Answer: While the above information could be put into a branch diagram, it does not easily fit into one and overcomplicates the problem, just as a Punnett square would.

4. In the pedigree, identify a mating that illustrates Mendel's first law.

Answer: The marriage between John's parents illustrates Mendel's first law.

5. Define all the scientific terms in the problem, and look up any other terms about which you are uncertain.

Answer: The scientific words in this problem are *galactosemia*, *autosomal*, and *recessive*.

*Galactosemia* is a metabolic disorder characterized by the absence of the enzyme galactose-1-phosphate uridyl transferase, which results in an accumulation of galactose. In the vast majority of cases, galactosemia results in an enlarged liver, jaundice, vomiting, anorexia, lethargy, and very early death if galactose is not omitted from the diet (initially, the child obtains galactose from milk).

*Autosomal* refers to genes that are on the autosomes.

*Recessive* means that, in order for an allele to be expressed, it must be the only form of the gene present in the organism.

6. What assumptions need to be made in answering this problem?

Answer: The major assumption is that, if nothing is stated about a person's phenotype, the person is of normal phenotype. Another assumption that may be of value, but is not actually needed, is that all people marrying into these two families are normal and do not carry the allele for galactosemia.

7. Which unmentioned family members must be considered? Why?

Answer: The people not mentioned in the problem but who must be considered are John's parents and Martha's grandparent and parent descended from her affected greatgrandmother.

8. What statistical rules might be relevant, and in what situations can they be applied? Do such situations exist in this problem?

Answer: The major statistical rule needed to solve the problem is the product rule (the "and" rule). It is used to calculate the cumulative probabilities described in part 2 of this unpacked

solution (e.g., What is the probability that Martha's parent inherited the galactosemia allele AND passed that allele on to Martha AND Martha will pass that allele on to her child?).

9. What are two generalities about autosomal recessive diseases in human populations?

Answer: Autosomal recessive disorders are assumed to be rare and to occur equally frequently in males and females. They are also assumed to be expressed if the person is homozygous for the recessive genotype.

10. What is the relevance of the rareness of the phenotype under study in pedigree analysis generally, and what can be inferred in this problem?

Answer: Rareness leads to the assumption that people who marry into a family that is being studied do not carry the allele, which was assumed in entry 6 above.

11. In this family, whose genotypes are certain and whose are uncertain?

Answer: The only certain genotypes in the pedigree are John's parents, John's brother, and Martha's great-grandmother and grandmother. All other individuals have uncertain genotypes.

12. In what way is John's side of the pedigree different from Martha's side? How does this difference affect your calculations?

Answer: John's family can be treated simply as a heterozygous-by-heterozygous cross, with John having a  $2/3$  probability of being a carrier, while it is unknown whether either of Martha's parents carry the allele. Therefore, Martha's chance of being a carrier must be calculated as a series of probabilities.

13. Is there any irrelevant information in the problem as stated?

Answer: The information regarding Martha's sister and her children turns out to be irrelevant to the problem.

14. In what way is solving this kind of problem similar to solving problems that you have already successfully solved? In what way is it different?

Answer: The problem contains a number of assumptions that have not been necessary in problem solving until now.

15. Can you make up a short story based on the human dilemma in this problem?

Answer: Many scenarios are possible in response to this question.

Now try to solve the problem. If you are unable to do so, try to identify the obstacle and write a sentence or two describing your difficulty. Then go back to the expansion questions and see if any of them relate to your difficulty.

### **Solution to the Problem**

Answer:  $p(\text{child has galactosemia}) = p(\text{John is } G/g) \times p(\text{Martha is } G/g) \times p(\text{both parents passed } g \text{ to the child}) = (2/3)(1/4)(1/4) = 2/48 = 1/24$

45. Holstein cattle are normally black and white. A superb black-and-white bull, Charlie, was purchased by a farmer for \$100,000. All the progeny sired by Charlie were normal in appearance. However, certain pairs of his progeny, when interbred, produced red-and-white progeny at a frequency of about 25 percent. Charlie was soon removed from the stud lists of the Holstein breeders. Use symbols to explain precisely why.

Answer: Charlie, his mate, or both, obviously were not homozygous for one of the alleles (pure-breeding) because his  $F_2$  progeny were of two phenotypes. Let  $A$  = black and white and  $a$  = red and white. If both parents were heterozygous, then red and white would have been expected in the  $F_1$  generation. Red and white were not observed in the  $F_1$  generation, so only one of the parents was heterozygous. The cross is:

$$\begin{array}{l} \text{P} \quad A/a \times A/A \\ \text{F}_1 \quad 1 A/a : 1 A/A \end{array}$$

Two  $F_1$  heterozygotes ( $A/a$ ) when crossed would give 1  $A/A$  (black and white):2  $A/a$  (black and white):1  $a/a$  (red and white). If the red and white  $F_2$  progeny were from more than one mate of Charlie's, then the farmer acted correctly. However, if the  $F_2$  progeny came only from one mate, the farmer may have acted too quickly.

46. Suppose that a husband and wife are both heterozygous for a recessive allele for albinism. If they have dizygotic (two-egg) twins, what is the probability that both the twins will have the same phenotype for pigmentation?

Answer: Because the parents are heterozygous, both are  $A/a$ . Both twins could be albino or both twins could be normal (and = multiply, or = add). The probability of being normal ( $A/-$ ) is  $3/4$ , and the probability of being albino ( $a/a$ ) is  $1/4$ .

$$\begin{aligned} & p(\text{both normal}) + p(\text{both albino}) \\ & p(\text{first normal}) \times p(\text{second normal}) + p(\text{first albino}) \times p(\text{second albino}) \\ & (3/4)(3/4) + (1/4)(1/4) = 9/16 + 1/16 = 5/8 \end{aligned}$$

47. The plant blue-eyed Mary grows on Vancouver Island and on the lower mainland of British Columbia. The populations are dimorphic for purple blotches on the leaves—some plants have blotches and others don't. Near Nanaimo, one plant in nature had blotched leaves. This plant, which had not yet flowered, was dug up and taken to a laboratory, where it was allowed to self. Seeds were collected



and grown into progeny. One randomly selected (but typical) leaf from each of the progeny is shown in the accompanying illustration.

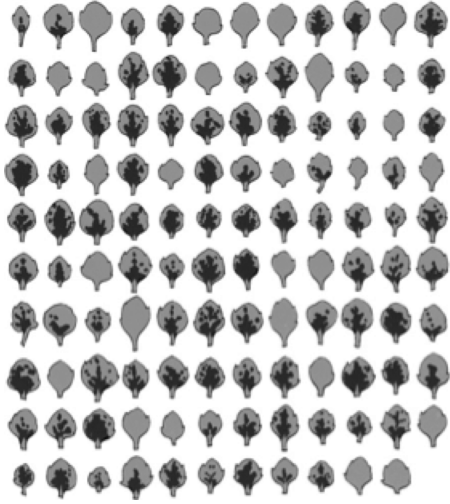

- a. Formulate a concise genetic hypothesis to explain these results. Explain all symbols and show all genotypic classes (and the genotype of the original plant).
- b. How would you test your hypothesis? Be specific.

Answer: The plants are approximately 3 blotched:1 unblotched. This suggests that blotched is dominant to unblotched and that the original plant, which was selfed, was a heterozygote.

- a. Let  $A$  = blotched,  $a$  = unblotched.

$$\begin{array}{l}
 \text{P} \quad A/a \text{ (blotched)} \times A/a \text{ (blotched)} \\
 \text{F}_1 \quad 1 A/A : 2 A/a : 1 a/a \\
 \quad \quad 3 A/- \text{ (blotched)} : 1 a/a \text{ (unblotched)}
 \end{array}$$

- b. All unblotched plants should be purebreeding in a testcross with an unblotched plant ( $a/a$ ), and one-third of the blotched plants should be purebreeding.

48. Can it ever be proved that an animal is not a carrier of a recessive allele (that is, not a heterozygote for a given gene)? Explain.

Answer: In theory, it cannot be proved that an animal is not a carrier for a recessive allele. However, in an  $A/- \times a/a$  cross, the more dominant-phenotype progeny produced, the less likely it is that the parent is  $A/a$ . In such a cross, half the progeny would be  $a/a$  and half would be  $A/a$ . With  $n$  dominant phenotype progeny, the probability that the parent is  $A/a$  is  $(1/2)^n$ . (DNA sequencing can be used to prove heterozygosity, but without sequence level information, the level of certainty is limited by sample size.)

49. In nature, the plant *Plectritis congesta* is dimorphic for fruit shape; that is, individual plants bear either wingless or winged fruits, as shown in the illustration. Plants were collected from nature before flowering and were crossed or selfed with the following results:

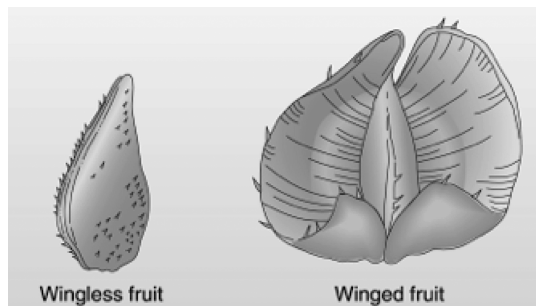

Pollination	Number of progeny	
	Winged	Wingless
Winged (selfed)	91	1*
Winged (selfed)	90	30
Wingless (selfed)	4*	80
Winged × wingless	161	0
Winged × wingless	29	31
Winged × wingless	46	0
Winged × winged	44	0
Winged × winged	24	0

\*Phenotype probably has a nongenetic explanation.

Interpret these results, and derive the mode of inheritance of these fruit-shaped phenotypes. Use symbols. What do you think is the nongenetic explanation for the phenotypes marked by asterisks in the table?

Answer: The results suggest that winged ( $A/-$ ) is dominant to wingless ( $a/a$ ) (cross 2 gives a 3:1 ratio). If that is correct, the crosses become:

Pollination	Genotypes	Number of progeny plants	
		Winged	Wingless
Winged (selfed)	$A/A \times A/A$	91	1*
Winged (selfed)	$A/a \times A/a$	90	30
Wingless (selfed)	$a/a \times a/a$	4*	80
Winged × wingless	$A/A \times a/a$	161	0
Winged × wingless	$A/a \times a/a$	29	31
Winged × wingless	$A/A \times a/a$	46	0
Winged × winged	$A/A \times A/-$	44	0
Winged × winged	$A/A \times A/-$	24	0

The five unusual plants are most likely due either to human error in classification or to contamination. Alternatively, they could result from environmental effects on development. For example, too little water may have prevented the seedpods from becoming winged, even though they are genetically winged.

50. The accompanying pedigree is for a rare but relatively mild hereditary disorder of the skin.

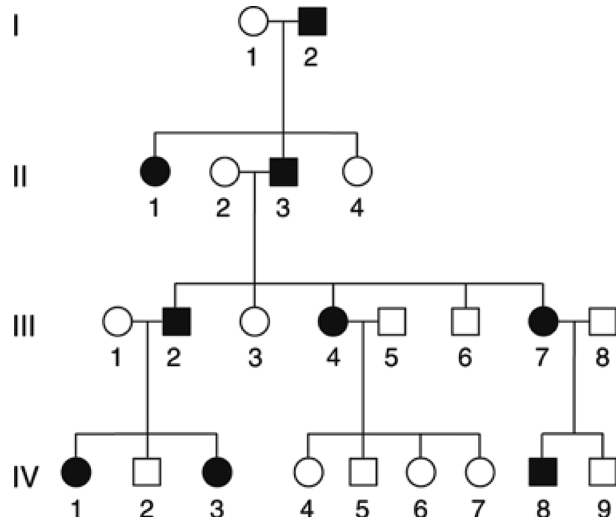

- How is the disorder inherited? State reasons for your answer.
- Give genotypes for as many individuals in the pedigree as possible. (Invent your own defined allele symbols.)
- Consider the four unaffected children of parents III-4 and III-5. In all four-child progenies from parents of these genotypes, what proportion is expected to contain all unaffected children?

Answer:

- The disorder appears to be dominant because all affected individuals have an affected parent. If the trait was recessive, then I-1, II-2, III-1, and III-8 would all have to be carriers (heterozygous for the rare allele).
- Assuming dominance, the genotypes are:  
 I:  $d/d$ ,  $D/d$   
 II:  $D/d$ ,  $d/d$ ,  $D/d$ ,  $d/d$   
 III:  $d/d$ ,  $D/d$ ,  $d/d$ ,  $D/d$ ,  $d/d$ ,  $d/d$ ,  $D/d$ ,  $d/d$   
 IV:  $D/d$ ,  $d/d$ ,  $D/d$ ,  $d/d$ ,  $d/d$ ,  $d/d$ ,  $d/d$ ,  $D/d$ ,  $d/d$
- The mating is  $D/d \times d/d$ . The probability of an affected child ( $D/d$ ) equals  $1/2$ , and the probability of an unaffected child ( $d/d$ ) equals  $1/2$ . Therefore, the chance of having four unaffected children (since each is an independent event) is  $1/2 \times 1/2 \times 1/2 \times 1/2 = 1/16$ .

51. Four human pedigrees are shown in the accompanying illustration. The black symbols represent an abnormal phenotype inherited in a simple Mendelian manner.

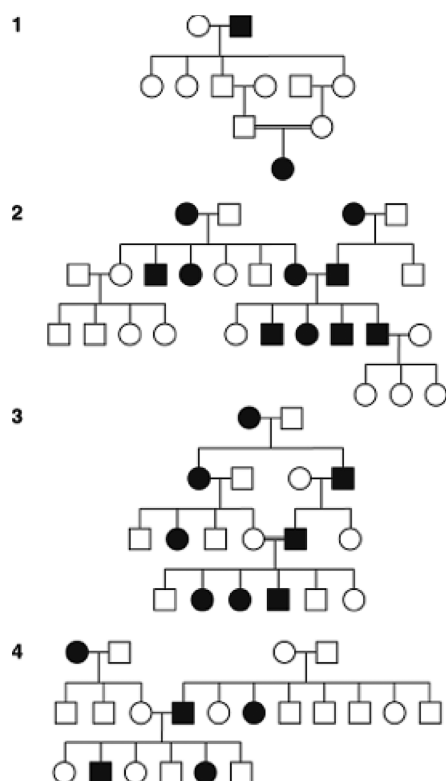

- For each pedigree, state whether the abnormal condition is dominant or recessive. Try to state the logic behind your answer.
- For each pedigree, describe the genotypes of as many persons as possible.

Answer:

- Pedigree 1*: The best answer is recessive because two unaffected individuals had affected progeny. Also, the disorder skips generations and appears in a mating between two related individuals.

*Pedigree 2*: The best answer is dominant because two affected parents have an unaffected child. Also, it appears in each generation, roughly half the progeny are affected, and all affected individuals have an affected parent.

*Pedigree 3*: The best answer is dominant, for many of the reasons stated for pedigree 2. Inbreeding, while present in the pedigree, does not allow an explanation of recessive because it cannot account for individuals in the second or third generations.

*Pedigree 4*: The best answer is recessive. Two unaffected individuals had affected progeny.

- Genotypes of pedigree 1:

Generation I:  $A/-$ ,  $a/a$

Generation II:  $A/a$ ,  $A/a$ ,  $A/a$ ,  $A/-$ ,  $A/-$ ,  $A/a$

Generation III:  $A/a$ ,  $A/a$

Generation IV:  $a/a$

Genotypes of pedigree 2:

Generation I:  $A/a, a/a, A/a, a/a$   
 Generation II:  $a/a, a/a, A/a, A/a, a/a, a/a, A/a, A/a, a/a$   
 Generation III:  $a/a, a/a, a/a, a/a, a/a, A/-, A/-, A/-, A/a, a/a$   
 Generation IV:  $a/a, a/a, a/a$

Genotypes of pedigree 3:

Generation I:  $A/-, a/a$   
 Generation II:  $A/a, a/a, a/a, A/a$   
 Generation III:  $a/a, A/a, a/a, a/a, A/a, a/a$   
 Generation IV:  $a/a, A/a, A/a, A/a, a/a, a/a$

Genotypes of pedigree 4:

Generation I:  $a/a, A/-, A/a, A/a$   
 Generation II:  $A/a, A/a, A/a, a/a, A/-, a/a, A/-, A/-, A/-, A/-, A/-$   
 Generation III:  $A/a, a/a, A/a, A/a, a/a, A/a$

52. Tay-Sachs disease is a rare human disease in which toxic substances accumulate in nerve cells. The recessive allele responsible for the disease is inherited in a simple Mendelian manner. For unknown reasons, the allele is more common in populations of Ashkenazi Jews of eastern Europe. A woman is planning to marry her first cousin, but the couple discovers that their shared grandfather's sister died in infancy of Tay-Sachs disease.
- Draw the relevant parts of the pedigree, and show all the genotypes as completely as possible.
  - What is the probability that the cousins' first child will have Tay-Sachs disease, assuming that all people who marry into the family are homozygous normal?

Answer:

- a. The pedigree is

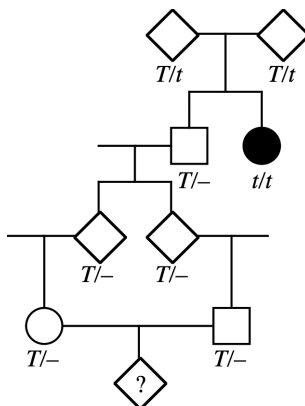

- b. The probability that the child of the two first cousins will have Tay-Sachs disease is a single calculation, first assessing the probability that the shared grandfather is a carrier ( $2/3$ , his parents were carriers) and then following the probabilities through to the male and female in question. If the grandfather is a carrier, then each of his children had a  $1/2$  probability of receiving the mutant allele. This consideration is again true for passing the allele to the male and female in question.

Finally, both the male and female in question must have the recessive allele if an affected child is to be born. If both are carriers, then that outcome would have a  $1/4$  probability.

Thus,  $(2/3)(1/2)^4(1/4) = 1/96$ .

To understand the probabilities of the first two events, see also the discussion for part 2 in problem 8 of this chapter.

53. The following pedigree was obtained for a rare kidney disease.

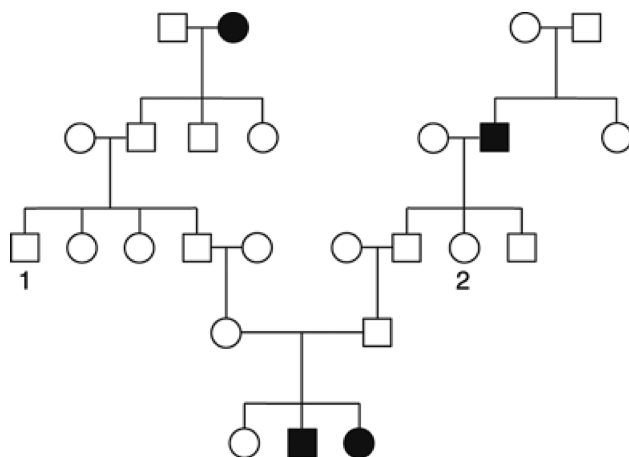

- Deduce the inheritance of this condition, stating your reasons.
- If persons 1 and 2 marry, what is the probability that their first child will have the kidney disease?

Answer:

- Autosomal recessive: affected individuals inherited the trait from unaffected parents and a daughter inherited the trait from an unaffected father.
- Both parents must be heterozygous to have a  $1/4$  chance of having an affected child. Parent 2 is heterozygous, since her father is homozygous for the recessive allele and parent 1 has a  $1/2$  chance of being heterozygous, since his father is heterozygous because 1's paternal grandmother was affected. Overall,  $1 \times 1/2 \times 1/4 = 1/8$ .

54. This pedigree is for Huntington disease, a late-onset disorder of the nervous system. The slashes indicate deceased family members.

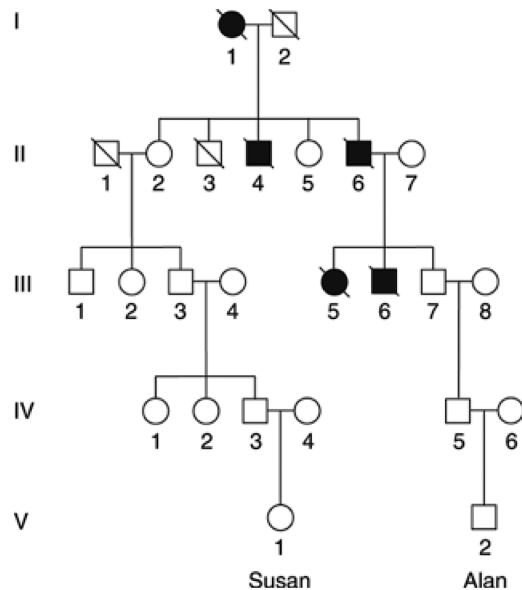

- Is this pedigree compatible with the mode of inheritance for Huntington disease mentioned in the chapter?
- Consider two newborn children in the two arms of the pedigree, Susan in the left arm and Alan in the right arm. Study the graph in Figure 2-24 and form an opinion on the likelihood that they will develop Huntington disease. Assume for the sake of the discussion that parents have children at age 25.

Answer:

- Yes. It is inherited as an autosomal dominant trait.
- Susan is highly unlikely to have Huntington's disease. Her great-grandmother (individual II-2) is 75 years old and has yet to develop it, when nearly 100 percent of people carrying the allele will have developed the disease by that age. If her great-grandmother does not have it, Susan cannot inherit it.

Alan is somewhat more likely than Susan to develop Huntington's disease. His grandfather (individual III-7) is only 50 years old, and approximately 20 percent of the people with the allele have yet to develop the disease by that age. Therefore, it can be estimated that the grandfather has a 10-percent chance of being a carrier (50-percent chance he inherited the allele from his father  $\times$  20-percent chance he has not yet developed symptoms). If Alan's grandfather eventually develops Huntington's disease, then there is a probability of 50 percent that Alan's father inherited it from him, and a probability of 50 percent that Alan received that allele from his father. Therefore, Alan has a  $1/10 \times 1/2 \times 1/2 = 1/40$  current probability of developing Huntington's disease and a  $1/2 \times 1/2 = 1/4$  probability if his grandfather eventually develops it.

55. Consider the accompanying pedigree of a rare autosomal recessive disease, PKU.

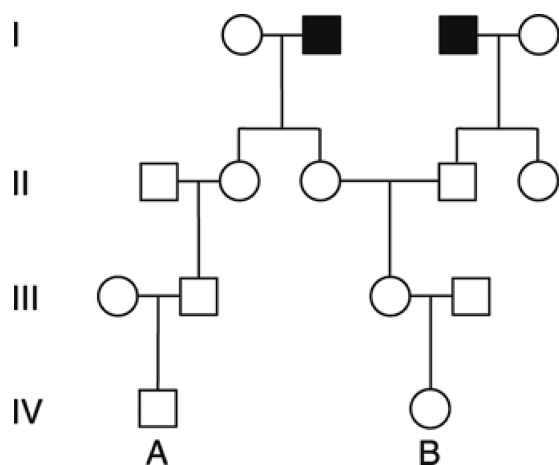

- List the genotypes of as many of the family members as possible.
  - If persons A and B marry, what is the probability that their first child will have PKU?
  - If their first child is normal, what is the probability that their second child will have PKU?
  - If their first child has the disease, what is the probability that their second child will be unaffected?
- (Assume that all people marrying into the pedigree lack the abnormal allele.)

Answer:

- Assuming the trait is rare, expect that all individuals marrying into the pedigree do not carry the disease-causing allele.

I:  $P/P, p/p, p/p, P/P$   
 II:  $P/P, P/p, P/p, P/p, P/p$   
 III:  $P/P, P/-, P/-, P/P$   
 IV:  $P/-, P/-$

- For their child to have PKU, both A and B must be carriers and both must donate the recessive allele.

The probability that individual A has the PKU allele is derived from individual II-2. II-2 must be  $P/p$  since her father must be  $p/p$ . Therefore, the probability that II-2 passed the PKU allele to individual III-2 is  $1/2$ . If III-2 received the allele, the probability that he passed it to individual IV-1 (A) is  $1/2$ . Therefore, the probability that A is a carrier is  $1/2 \times 1/2 = 1/4$ .

The probability that individual B has the allele goes back to the mating of II-3 and II-4, both of whom are heterozygous. Their child, III-3, has a  $2/3$  probability of having received the PKU allele and a probability of  $1/2$  of passing it to IV-2 (B). Therefore, the probability that B has the PKU allele is  $2/3 \times 1/2 = 1/3$ .

If both parents are heterozygous, they have a  $1/4$  chance of both passing the  $p$  allele to their child.  
 $p(\text{child has PKU}) = p(\text{A is } P/p) \times p(\text{B is } P/p) \times p(\text{both parents donate } p)$

$$\frac{1}{4} \times \frac{1}{3} \times \frac{1}{4} = \frac{1}{48}$$



- c. If the first child is normal, no additional information has been gained and the probability that the second child will have PKU is the same as the probability that the first child will have PKU, or  $1/48$ .
- d. If the first child has PKU, both parents are heterozygous. The probability of having an affected child is now  $1/4$ , and the probability of having an unaffected child is  $3/4$ .

56. A man has attached earlobes, whereas his wife has free earlobes. Their first child, a boy, has attached earlobes.
- a. If the phenotypic difference is assumed to be due to two alleles of a single gene, is it possible that the gene is X-linked?
- b. Is it possible to decide if attached earlobes are dominant or recessive?

Answer:

- a. Sons inherit their X chromosome from their mother. The mother has earlobes, the son does not. If the allele for earlobes is dominant and the allele for lack of earlobes recessive, then the mother could be heterozygous for this trait and the gene could be X-linked.
- b. It is not possible from the data given to decide which allele is dominant. If lack of earlobes is dominant, then the father would be heterozygous and the son would have a 50-percent chance of inheriting the dominant “lack-of-earlobes” allele. If lack of earlobes is recessive, then the trait could be autosomal or X-linked, but in either case, the mother would be heterozygous.

57. A rare recessive allele inherited in a Mendelian manner causes the disease cystic fibrosis. A phenotypically normal man whose father had cystic fibrosis marries a phenotypically normal woman from outside the family, and the couple consider having a child.
- a. Draw the pedigree as far as described.
- b. If the frequency in the population of heterozygotes for cystic fibrosis is 1 in 50, what is the chance that the couple’s first child will have cystic fibrosis?
- c. If the first child does have cystic fibrosis, what is the probability that the second child will be normal?

Answer:

- a. Let  $C$  stand for the normal allele and  $c$  stand for the allele that causes cystic fibrosis.

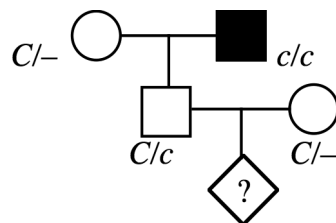

- b. The man has a 100-percent probability of having the  $c$  allele. His wife, who is from the general population, has a  $1/50$  chance of having the  $c$  allele. If both have the allele, then  $1/4$  of their children will have cystic fibrosis. The probability that their first child will have cystic fibrosis is:

$$p(\text{man has } c) \times p(\text{woman has } c) \times p(\text{both pass } c \text{ to the child})$$

$$1.0 \quad \times \quad 1/50 \quad \times \quad 1/4 = 1/200 = 0.005$$

- c. If the first child does have cystic fibrosis, then the woman is a carrier of the  $c$  allele. Because both parents are  $C/c$ , the chance that the second child will be normal is the probability of a normal child in a heterozygous  $\times$  heterozygous mating, or  $3/4$ .
58. The allele  $c$  causes albinism in mice ( $C$  causes mice to be black). The cross  $C/c \times c/c$  produces 10 progeny. What is the probability of all of them being black?

Answer: The cross is  $C/c \times c/c$ , so there is a  $1/2$  chance that a progeny would be black ( $C/c$ ). Because each progeny's genotype is independent of the others, the chance that all 10 progeny are black is  $(1/2)^{10}$ .

59. The recessive allele  $s$  causes *Drosophila* to have small wings and the  $s^+$  allele causes normal wings. This gene is known to be X-linked. If a small-winged male is crossed with a homozygous wild-type female, what ratio of normal to small-winged flies can be expected in each sex in the  $F_1$ ? If  $F_1$  flies are intercrossed, what  $F_2$  progeny ratios are expected? What progeny ratios are predicted if  $F_1$  females are backcrossed with their father?

Answer:

P	$s^+/s^+$	$\times$	$s/Y$	
				↓
F <sub>1</sub>	$1/2 s^+/s$			normal female
	$1/2 s^+/Y$			normal male
	$s^+/s$	$\times$	$s^+/Y$	
				↓
F <sub>2</sub>	$1/4 s^+/s^+$			normal female
	$1/4 s^+/s$			normal female
	$1/4 s^+/Y$			normal male
	$1/4 s/Y$			small-winged male

P	$s^+/s$	$\times$	$s/Y$	
				↓
Progeny	$1/4 s^+/s$			normal female
	$1/4 s/s$			small-winged female
	$1/4 s^+/Y$			normal male
	$1/4 s/Y$			small-winged male

60. An X-linked dominant allele causes hypophosphatemia in humans. A man with hypophosphatemia marries a normal woman. What proportion of their sons will have hypophosphatemia?

Answer: Let  $H$  = hypophosphate and  $h$  = normal. The cross is  $H/Y \times h/h$ , yielding  $H/h$  (females) and  $h/Y$  (males). The answer is 0 percent because sons always inherit an X chromosome from their mothers and a Y chromosome from their fathers.

61. Duchenne muscular dystrophy is sex-linked and usually affects only males. Victims of the disease become progressively weaker, starting early in life.
- What is the probability that a woman whose brother has Duchenne's disease will have an affected child?
  - If your mother's brother (your uncle) had Duchenne's disease, what is the probability that you have received the allele?
  - If your father's brother had the disease, what is the probability that you have received the allele?

Answer:

- a. You should draw pedigrees for this question.

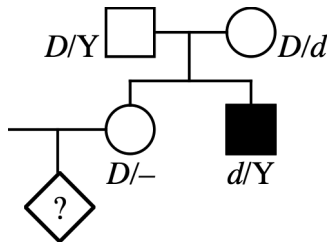

The “maternal grandmother” had to be a carrier,  $D/d$ . The probability that the woman inherited the  $d$  allele from her is  $1/2$ . The probability that she passes it to her child is  $1/2$ . The probability that the child is male is  $1/2$ . The total probability of the woman having an affected child is  $1/2 \times 1/2 \times 1/2 = 1/8$ .

- b. The pedigree in part (a) applies. The “maternal grandmother” had to be a carrier,  $D/d$ . The probability that your mother received the allele is  $1/2$ . The probability that your mother passed it to you is  $1/2$ . The total probability is  $1/2 \times 1/2 = 1/4$ .
- c.

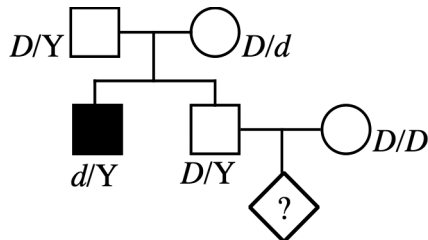

Because your father does not have the disease, you cannot inherit the allele from him. Therefore, the probability of inheriting an allele will be based on the chance that your mother is heterozygous. Since she is “unrelated” to the pedigree, assume that this is zero.

62. A recently married man and woman discover that each had an uncle with alkaptonuria, otherwise known as “black urine disease,” a rare disease caused by an autosomal recessive allele of a single gene. They are about to have their first baby. What is the probability that their child will have alkaptonuria?

Answer: For the recently married man and woman to each have an uncle with alkaptonuria means that each may have one parent (the parent related to the uncle) that is heterozygous for the disease-causing allele. Specifically, this parent (and related uncle) must have had parents that were both heterozygous for alkaptonuria. Any child of parents that are both heterozygous for a recessive trait, but does not have that trait, has a  $2/3$  chance of being heterozygous. (Remember, if both parents are heterozygous, we expect a 1:2:1 ratio of genotypes, but once we know a person is not homozygous recessive, the only possibilities left are 1 (homozygous dominant) to 2 (heterozygous), or  $2/3$  chance of being heterozygous.) So the man and woman each have a  $2/3 \times 1/2 = 1/3$  of being carriers (heterozygous), and the chance of their having an affected child would be  $1/3 \times 1/3 \times 1/4 = 1/36$ .

63. The accompanying pedigree concerns an inherited dental abnormality, *amelogenesis imperfecta*.

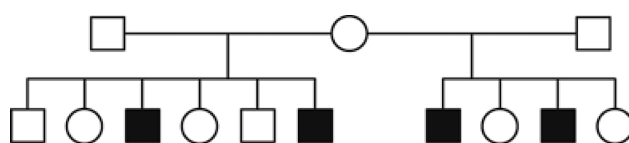

- What mode of inheritance best accounts for the transmission of this trait?
- Write the genotypes of all family members according to your hypothesis.

Answer:

- Because none of the parents is affected, the disease must be recessive. Because the inheritance of this trait appears to be sex-specific, it is most likely Xlinked. If it were autosomal, all three parents would have to be carriers, and by chance, only sons and none of the daughters inherited the trait (which is quite unlikely).
- $A/Y, A/a, A/Y$
  - $A/Y, A/-, a/Y, A/-, A/Y, a/Y, a/Y, A/-, a/Y, A/-$

64. A couple who are about to get married learn from studying their family histories that, in both their families, their unaffected grandparents had siblings with cystic fibrosis (a rare autosomal recessive disease).
- If the couple marries and has a child, what is the probability that the child will have cystic fibrosis?
  - If they have four children, what is the chance that the children will have the precise Mendelian ratio of 3:1 for normal:cystic fibrosis?
  - If their first child has cystic fibrosis, what is the probability that their next three children will be normal?

Answer:

- This question is similar to question 62, but this time the discussion begins with the grandparents rather than the parents. Again, given that a sibling is affected with a recessive disease, the related unaffected brother/sister will have a  $2/3$  chance of being heterozygous. In this case, that is one of the grandparents of both the man and woman about to be married. Given this, the couple will both have a  $2/3 \times 1/2 \times 1/2 = 1/6$  chance of being carriers (heterozygous) and the chance of their having an affected child will be

$$1/6 \times 1/6 \times 1/4 = 1/144.$$

- b. If both parents are carriers, there is a  $3/4$  chance a child will be normal and a  $1/4$  chance a child will have cystic fibrosis. Each child is an independent event, but since birth order is not considered, there are four ways to have the desired outcome. The child with cystic fibrosis may be the first, second, third, or fourth, so assuming the first is affected, the specified outcome would be a  $1/4 \times 3/4 \times 3/4 \times 3/4$ , or a  $27/256$  chance. Now, taking into account the four possible birth orders and the chance that both parents are heterozygous, the chance of an exact 3:1 ratio becomes  $4 \times 1/6 \times 1/6 \times 27/256 = 3/256$ .
- c. In this case, knowing the first child has cystic fibrosis lets us now deduce that the parents must both be heterozygous. Given this, there is a  $3/4$  chance than any future child will be normal. Since each is independent, the chance that their next three are normal is simply  $3/4 \times 3/4 \times 3/4$ , or  $27/64$ .
65. A sex-linked recessive allele  $c$  produces red–green color blindness in humans. A normal woman whose father was color-blind marries a color-blind man.
- What genotypes are possible for the mother of the color-blind man?
  - What are the chances that the first child from this marriage will be a color-blind boy?
  - Of the girls produced by these parents, what proportion can be expected to be color-blind?
  - Of all the children (sex unspecified) of these parents, what proportion can be expected to have normal color vision?

Answer:

You should draw the pedigree before beginning.

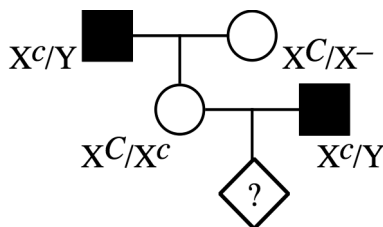

- $X^C/X^c$ ,  $X^c/X^c$
  - $p(\text{color-blind}) \times p(\text{male}) = (1/2)(1/2) = 1/4$
  - The girls will be 1 normal ( $X^C/X^c$ ):1 color-blind ( $X^c/X^c$ ).
  - The cross is  $X^C/X^c \times X^c/Y$ , yielding 1 normal:1 color-blind for both sexes.
66. Male house cats are either black or orange; females are black, orange, or calico.
- If these coat-color phenotypes are governed by a sex-linked gene, how can these observations be explained?
  - Using appropriate symbols, determine the phenotypes expected in the progeny of a cross between an orange female and a black male.
  - Half the females produced by a certain kind of mating are calico, and half are black; half the males are orange, and half are black. What colors are the parental males and females in this kind of mating?
  - Another kind of mating produces progeny in the following proportions: one-fourth orange males, one-fourth orange females, one-fourth black males, and one-fourth calico females. What colors are the parental males and females in this kind of mating?

Answer:

- a. This problem involves X inactivation. Let  $B$  = black and  $b$  = orange.

Females	Males
$X^B/X^B$ = black	$X^B/Y$ = black
$X^b/X^b$ = orange	$X^b/Y$ = orange
$X^B/X^b$ = calico	

- b. P  $X^b/X^b$ (orange)  $\times$   $X^B/Y$ (black)  
 F<sub>1</sub>  $X^B/X^b$ (calico female)  
 $X^b/Y$ (orange male)
- c. Because the males are black or orange, the mother had to have been calico. Half the daughters are black, indicating that their father was black.
- d. Males were orange or black, indicating that the mothers were calico. Orange females indicate that the father was orange.

67. The pedigree below concerns a certain rare disease that is incapacitating but not fatal.

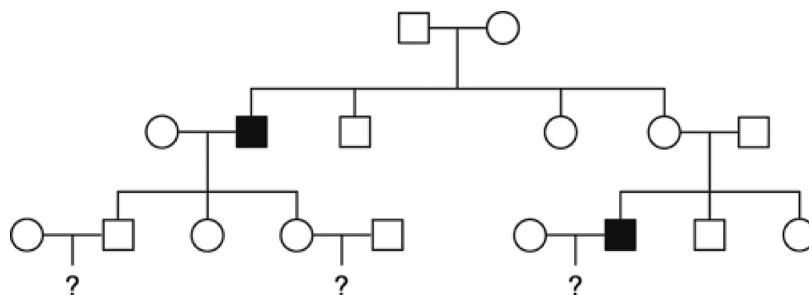

- a. Determine the most likely mode of inheritance of this disease.
- b. Write the genotype of each family member according to your proposed mode of inheritance.
- c. If you were this family's doctor, how would you advise the three couples in the third generation about the likelihood of having an affected child?

Answer:

- a. Recessive (unaffected parents have affected progeny) and Xlinked (only assumption is that the grandmother, I-2, is a carrier). If autosomal, then I-1, I-2, and II-6 would all have to be carriers.
- b. Generation I:  $X^A/Y$ ,  $X^A/X^a$   
 Generation II:  $X^A/X^A$ ,  $X^a/Y$ ,  $X^A Y$ ,  $X^A/X^-$ ,  $X^A/X^a$ ,  $X^A/Y$   
 Generation III:  $X^A/X^A$ ,  $X^A/Y$ ,  $X^A/X^a$ ,  $X^A/X^a$ ,  $X^A/Y$ ,  $X^A X^A$ ,  $X^a/Y$ ,  $X^A/Y$ ,  $X^A/X^-$
- c. Because it is stated that the trait is rare, the assumption is that no one marrying into the pedigree carries the recessive allele. Therefore, the first couple has no chance of an affected child because the son received a Y chromosome from his father. The second couple has a 50 percent chance of having affected sons and no chance of having affected daughters. The third couple has no chance of having an affected child, but all their daughters will be carriers.

68. In corn, the allele  $s$  causes sugary endosperm, whereas  $S$  causes starchy. What endosperm genotypes result from each of the following crosses?
- $s/s$  female  $\times$   $S/S$  male
  - $S/S$  female  $\times$   $s/s$  male
  - $S/s$  female  $\times$   $S/s$  male

Answer: Remember, the endosperm is formed from two polar nuclei (which are genetically identical) and one sperm nucleus.

Female	Male	Polar nuclei	Sperm	Endosperm
$s/s$	$S/S$	$s$ and $s$	$S$	$S/s/s$
$S/S$	$s/s$	$S$ and $S$	$s$	$S/S/s$
$S/s$	$S/s$	$1/2 S$ and $S$	$1/2 S$	$1/4 S/S/S$
				$1/4 S/S/s$
		$1/2 s$ and $s$	$1/2 s$	$1/4 S/s/s$
				$1/4 s/s/s$

69. A plant geneticist has two pure lines, one with purple petals and one with blue. She hypothesizes that the phenotypic difference is due to two alleles of one gene. To test this idea, she aims to look for a 3:1 ratio in the  $F_2$ . She crosses the lines and finds that all the  $F_1$  progeny are purple. The  $F_1$  plants are selfed and 400  $F_2$  plants are obtained. Of these  $F_2$  plants, 320 are purple and 80 are blue. Do these results fit her hypothesis well? If not, suggest why.

Answer: This ratio looks to be 4:1 rather than 3:1. A number of reasons may cause this difference: simple chance occurrences, diminished health in the plants displaying the blue flowers, experimental error, or perhaps more than one gene is involved with this trait. In Chapter 3, we will introduce statistical methods to quantitatively evaluate whether data that diverges from expected is likely due to chance or if the divergence is so significant that the hypothesis is considered inconsistent with the data.



70. A man's grandfather has galactosemia, a rare autosomal recessive disease caused by the inability to process galactose, leading to muscle, nerve, and kidney malfunction. The man married a woman whose sister had galactosemia. The woman is now pregnant with their first child.
- Draw the pedigree as described.
  - What is the probability that this child will have galactosemia?
  - If the first child does have galactosemia, what is the probability that a second child will have it?

### Solution to the Problem

Answer:

- Galactosemia pedigree

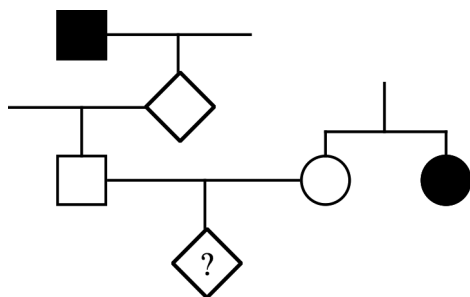

- b. Both parents must be heterozygous for this child to have a  $1/4$  chance of inheriting the disease. Since the mother's sister is affected with galactosemia, their parents must have both been heterozygous. Since the mother does not have the trait, there is a  $2/3$  chance that she is a carrier (heterozygous). One of the father's parents must be a carrier since his grandfather had the recessive trait. Thus, the father had a  $1/2$  chance of inheriting the allele from that parent. Since these are all independent events, the child's risk is:

$$1/4 \times 2/3 \times 1/2 = 1/12$$

- c. If the child has galactosemia, both parents must be carriers and thus those probabilities become 100 percent. Now all future children have a  $1/4$  chance of inheriting the disease.

## CHALLENGING PROBLEMS

71. A geneticist working on peas has a single plant monohybrid  $Y/y$  (yellow) and, from a self of this plant, wants to produce a plant of genotype  $y/y$  to use as a tester. How many progeny plants need to be grown to be 95 percent sure of obtaining at least one in the sample?

Answer: The probability of obtaining  $y/y$  from this cross is  $1/4$ , and the probability of not obtaining it is  $3/4$ . Since only one plant is needed, the probability of not getting this genotype in  $n$  trials is  $(3/4)^n$ . Because the probability of failure must be no greater than 5 percent:

$$(3/4)^n = 0.05$$

$$\log(3/4)^n = \log 0.05$$

$$n = \log 0.05 / \log(3/4)$$

$$n = 10.4 \text{ plants; 11 or more plants need to be sampled}$$

72. A curious polymorphism in human populations has to do with the ability to curl up the sides of the tongue to make a trough ("tongue rolling"). Some people can do this trick, and others simply cannot. Hence, it is an example of a dimorphism. Its significance is a complete mystery. In one family, a boy was unable to roll his tongue but, to his great chagrin, his sister could. Furthermore, both his parents were rollers, and so were both grandfathers, one paternal uncle, and one paternal aunt. One paternal aunt, one paternal uncle, and one maternal uncle could not roll their tongues.
- Draw the pedigree for this family, defining your symbols clearly, and deduce the genotypes of as many individual members as possible.
  - The pedigree that you drew is typical of the inheritance of tongue rolling and led geneticists to come up with the inheritance mechanism that no doubt you came up with. However, in a study of



33 pairs of identical twins, both members of 18 pairs could roll, neither member of 8 pairs could roll, and one of the twins in 7 pairs could roll but the other could not. Because identical twins are derived from the splitting of one fertilized egg into two embryos, the members of a pair must be genetically identical. How can the existence of the seven discordant pairs be reconciled with your genetic explanation of the pedigree?

Answer:

- a. In order to draw this pedigree, you should realize that, if an individual's status is not mentioned, then there is no way to assign a genotype to that person. The parents of the boy in question had a phenotype (and genotype) that differed from his. Therefore, both parents were heterozygous and the boy, who is a nonroller, is homozygous recessive. Let  $R$  stand for the ability to roll the tongue and  $r$  stand for the inability to roll the tongue. The pedigree becomes:

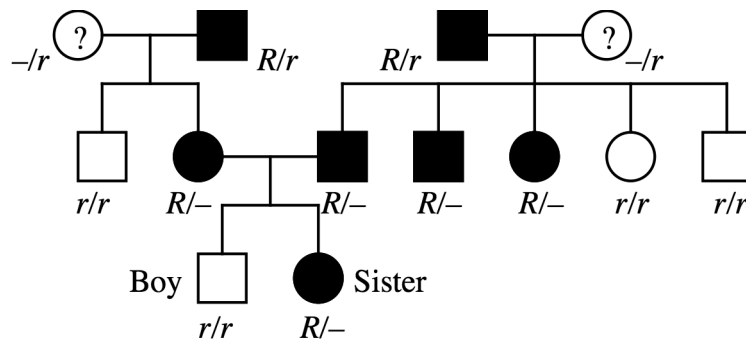

- b. Assuming the twins are identical, there might be either an environmental component to the expression of that gene or developmental noise (see Chapter 1). Another possibility is that the  $R$  allele is not fully penetrant and that some genotypic “rollers” do not express the phenotype.

73. Red hair runs in families, as in the following pedigree. (Pedigree data from W. R. Singleton and B. Ellis, *Journal of Heredity* 55, 1964, 261.)

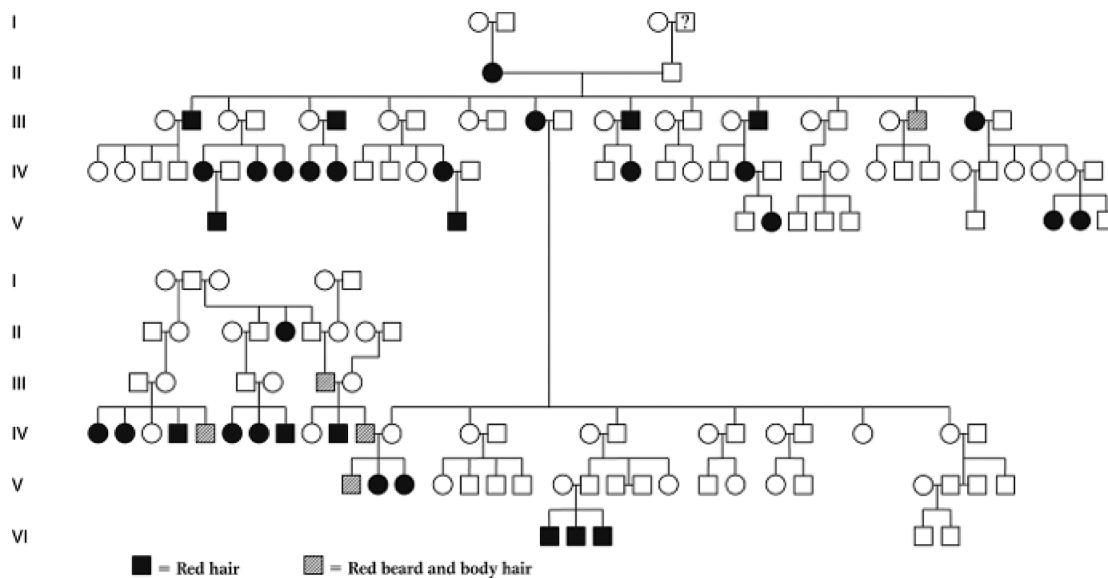

- a. Does the inheritance pattern in this pedigree suggest that red hair could be caused by a dominant or a recessive allele of a gene that is inherited in a simple Mendelian manner?
- b. Do you think that the red-hair allele is common or rare in the population as a whole?

Answer:

- a. The inheritance pattern for red hair suggested by this pedigree is recessive since most red-haired individuals are from parents without this trait.
  - b. In most populations, the allele appears to be somewhat rare.
74. When many families were tested for the ability to taste the chemical phenylthiocarbamide, the matings were grouped into three types and the progeny were totaled, with the results shown below:

Parents	Children		
	Number of families	Tasters	Nontasters
Taster $\times$ taster	425	929	130
Taster $\times$ nontaster	289	483	278
Nontaster $\times$ nontaster	86	5	218

With the assumption that PTC tasting is dominant ( $P$ ) and nontasting is recessive ( $p$ ), how can the progeny ratios in each of the three types of mating be accounted for?

Answer: *Taster-by-taster cross*: Tasters can be either  $T/T$  or  $T/t$ , and the genotypic status cannot be determined until a large number of offspring are observed. A failure to obtain a 3:1 ratio in the marriage of two tasters would be expected because there are three types of marriages:

Mating	Genotypes	Phenotypes
$T/T \times T/T$	all $T/T$	all tasters
$T/T \times T/t$	1 $T/T$ :1 $T/t$	all tasters
$T/t \times T/t$	1 $T/T$ :2 $T/t$ :1 $t/t$	3 tasters:1 nontaster

*Taster-by-nontaster cross*: There are two types of mating that resulted in the observed progeny:

Mating	Genotypes	Phenotypes
$T/T \times t/t$	all $T/t$	all tasters
$T/t \times t/t$	1 $T/t$ :1 $t/t$	1 tasters:1 nontaster

Again, the failure to obtain either a 1:0 ratio or a 1:1 ratio would be expected because of the two mating types.

*Nontaster-by-nontaster cross*: There is only one mating that is nontaster by nontaster ( $t/t \times t/t$ ), and 100 percent of the progeny would be expected to be nontasters. Of 223 children, five were classified as tasters. Some could be the result of mutation (unlikely), some could be the result of misclassification (likely), some could be the result of a second gene that affects the expression of the gene in question (possible), some could be the result of developmental noise (possible), and some could be due to illegitimacy (possible).

75. A condition known as *ichthyosis hystrix gravior* appeared in a boy in the early eighteenth century. His skin became very thick and formed loose spines that were sloughed off at intervals. When he grew up, this “porcupine man” married and had six sons, all of whom had this condition, and several daughters, all of whom were normal. For four generations, this condition was passed from father to son. From this evidence, what can you postulate about the location of the gene?

Answer: If the historical record is accurate, the data suggest Y linkage. Another explanation is an autosomal gene that is dominant in males and recessive in females. This has been observed for other genes in both humans and other species.

76. The wild-type (W) *Abraxas* moth has large spots on its wings, but the lacticolor (L) form of this species has very small spots. Crosses were made between strains differing in this character, with the following results:

Cross	Parents		Progeny	
	♀	♂	F <sub>1</sub>	F <sub>2</sub>
1	L	W	♀ W ♂ W	♀ $\frac{1}{2}$ L, $\frac{1}{2}$ W ♂ W
2	W	L	♀ L ♂ W	♀ $\frac{1}{2}$ W, $\frac{1}{2}$ L ♂ $\frac{1}{2}$ W, $\frac{1}{2}$ L

Provide a clear genetic explanation of the results in these two crosses, showing the genotypes of all individual moths.

Answer: The different sex-specific phenotypes found in the F<sub>1</sub> indicate sex linkage—the females inherit the trait of their fathers. The first cross also indicates that the wild-type large spots are dominant over the lacticolor small spots. Let *A* = wild type and *a* = lacticolor.

Cross 1: If the male is assumed to be the hemizygous sex, then it soon becomes clear that the predictions do not match what was observed:

P  $a/a$  female  $\times$   $A/Y$  male

F<sub>1</sub>  $A/a$  wild-type females  
 $a/Y$  lacticolor males

Therefore, assume that the female is the hemizygous sex. Let *Z* stand for the sex-determining chromosome in females. The cross becomes:

P  $a/Z$  female  $\times$   $A/A$  male

F<sub>1</sub>  $A/a$  wild-type male  
 $A/Z$  wild-type female

$F_2$	$1/4$	$A/Z$	wild-type females
	$1/2$	$A/-$	wild-type males
	$1/4$	$a/Z$	lacticolor females

Cross 2:

P	$A/Z$ female $\times$ $a/a$ male		
$F_1$	$a/Z$	lacticolor females	
	$A/a$	wild-type males	
$F_2$	$1/4$	$A/Z$	wild-type females
	$1/4$	$A/a$	wild-type males
	$1/4$	$a/Z$	lacticolor females
	$1/4$	$a/a$	lacticolor males

77. The following pedigree shows the inheritance of a rare human disease. Is the pattern best explained as being caused by an X-linked recessive allele or by an autosomal dominant allele with expression limited to males?

(Pedigree data from J. F. Crow, *Genetics Notes*, 6th ed. Copyright 1967 by Burgess Publishing Co., Minneapolis.)

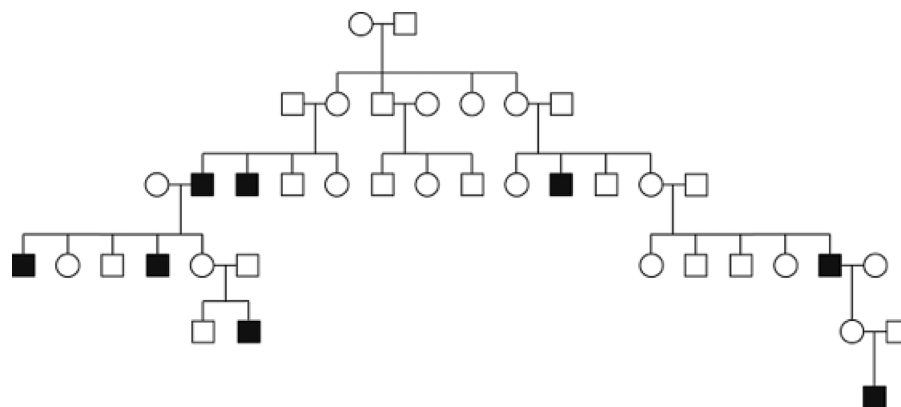

Answer: Note that only males are affected and that in all but one case, the trait can be traced through the female side. However, there is one example of an affected male having affected sons. If the trait is X-linked, this male's wife must be a carrier. Depending on how rare this trait is in the general population, this suggests that the disorder is caused by an autosomal dominant with expression limited to males.

78. A certain type of deafness in humans is inherited as an X-linked recessive trait. A man who suffers from this type of deafness married a normal woman, and they are expecting a child. They find out that they are distantly related. Part of the family tree is shown here.

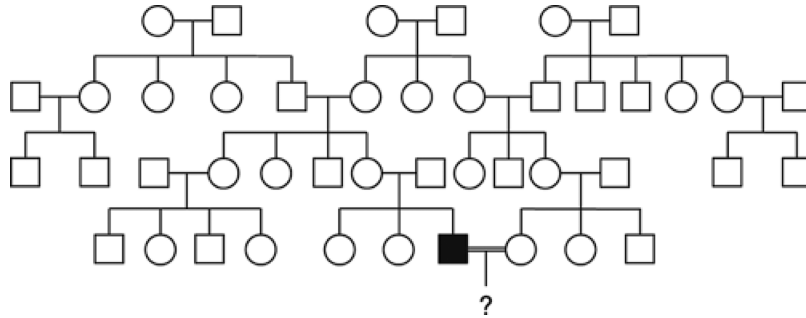

How would you advise the parents about the probability of their child being a deaf boy, a deaf girl, a normal boy, or a normal girl? Be sure to state any assumptions that you make.

Answer: Because the disorder is X-linked recessive, the affected male had to have received the allele,  $a$ , from the female common ancestor in the first generation. The probability that the affected man's wife also carries the  $a$  allele is the probability that she also received it from the female common ancestor. That probability is  $1/8$ .

The probability that the couple will have an affected boy is:

$$p(\text{father donates } Y) \times p(\text{the mother has } a) \times p(\text{mother donates } a) \\ 1/2 \times 1/8 \times 1/2 = 1/32$$

The probability that the couple will have an affected girl is:

$$p(\text{father donates } X^a) \times p(\text{the mother has } a) \times p(\text{mother donates } a) \\ 1/2 \times 1/8 \times 1/2 = 1/32$$

The probability of normal children is:

$$= 1 - p(\text{affected children}) \\ = 1 - p(\text{affected male}) - p(\text{affected female}) \\ = 1 - 1/32 - 1/32 = 30/32 = 15/16$$

Half the normal children will be boys, with a probability of  $15/32$ , and half the normal children will be girls, with a probability of  $15/32$ .

79. The accompanying pedigree shows a very unusual inheritance pattern that actually did exist. All progeny are shown, but the fathers in each mating have been omitted to draw attention to the remarkable pattern.

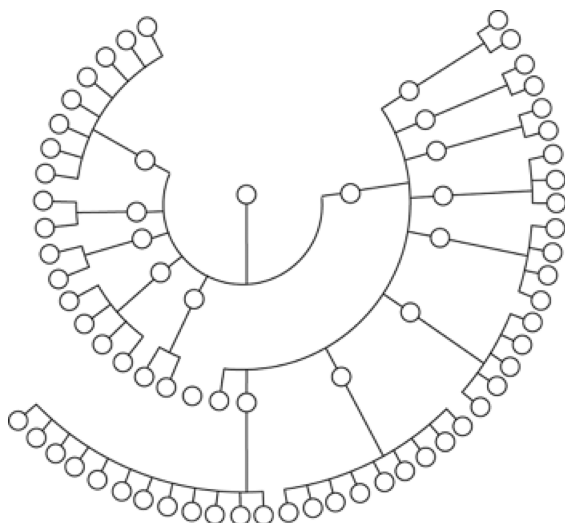

- Concisely state exactly what is unusual about this pedigree.
- Can the pattern be explained by Mendelian inheritance?

Answer:

- The complete absence of male offspring is the unusual aspect of this pedigree. In addition, all progeny that mate carry the trait for lack of male offspring. If the male lethality factor were nuclear, the male parent would be expected to alter this pattern. Therefore, cytoplasmic inheritance is suggested.
- If all females resulted from chance alone, then the probability of this result is  $(1/2)^n$ , where  $n$  = the number of female births. In this case  $n$  are 72. Chance is an unlikely explanation for the observations.

The observations can be explained by cytoplasmic factors by assuming that the proposed mutation in mitochondria is lethal only in males.

A modified form of Mendelian inheritance, an autosomal dominant, sex-limited lethal trait, might also explain these data, but it is an unlikely answer, due to the probability arguments above.