

## Ch. 1 Graphs, Equations, and Inequalities

### 1.1 The Distance and Midpoint Formulas; Graphing Utilities; Introduction to Graphing Equations

#### 1 Use the Distance Formula

**MULTIPLE CHOICE.** Choose the one alternative that best completes the statement or answers the question.

Find the distance  $d(P_1, P_2)$  between the points  $P_1$  and  $P_2$ .

1)

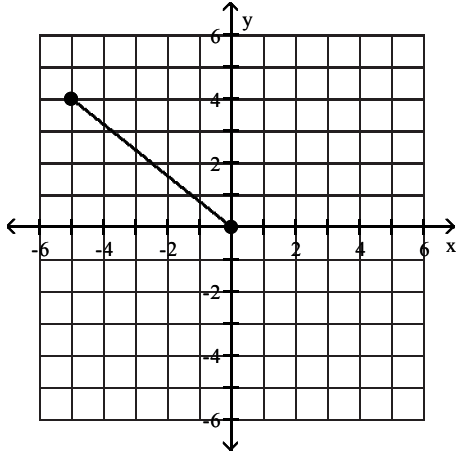

A)  $\sqrt{41}$

B) 3

C) 10

D) 8

2)

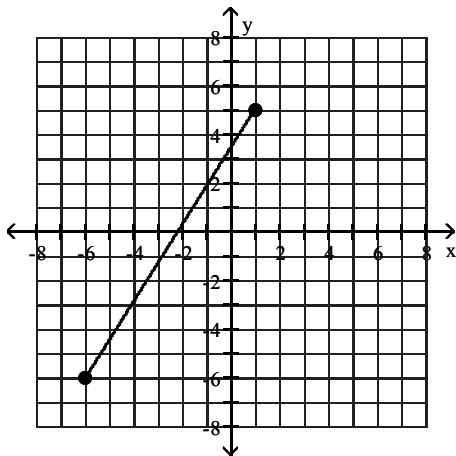

A)  $\sqrt{170}$

B)  $6\sqrt{2}$

C) 77

D) 4

3)

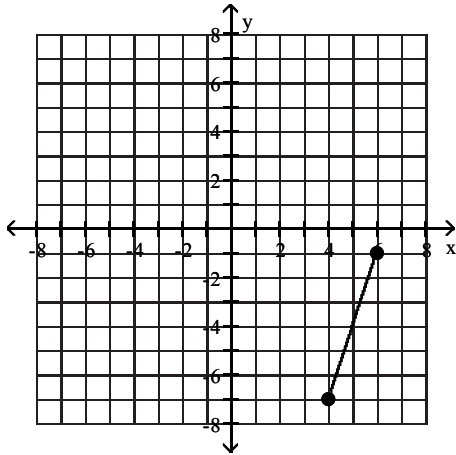

A)  $2\sqrt{10}$

B)  $32\sqrt{2}$

C) 32

D) 4

4)

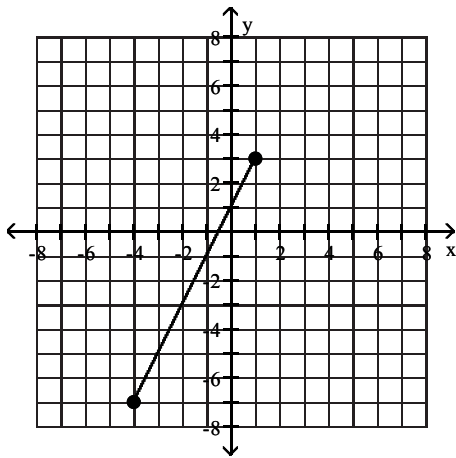

A)  $5\sqrt{5}$

B)  $75\sqrt{3}$

C) 75

D) 5

5)  $P_1 = (-2, -2); P_2 = (-2, -5)$

A) 3

B)  $\sqrt{3}$

C) 4

D) 2

6)  $P_1 = (-3, -3); P_2 = (-8, 9)$

A) 13

B) 169

C) 14

D) 26

7)  $P_1 = (0, -2); P_2 = (-4, -2)$

A) 4

B) 2

C)  $2\sqrt{5}$

D) 16

8)  $P_1 = (0, 0); P_2 = (-6, -9)$

A)  $3\sqrt{13}$

B) 117

C) 15

D)  $3i\sqrt{6}$

9)  $P_1 = (2, 1); P_2 = (-2, -6)$

A)  $\sqrt{65}$

B)  $\sqrt{33}$

C) 28

D) 3

10)  $P_1 = (5, -7); P_2 = (3, -3)$

A)  $2\sqrt{5}$

B)  $12\sqrt{3}$

C) 12

D) 6

- 11)  $P_1 = (-6, -4)$ ;  $P_2 = (4, -6)$   
 A)  $2\sqrt{26}$                       B)  $96\sqrt{6}$                       C) 96                      D) 12
- 12)  $P_1 = (-0.9, -0.2)$ ;  $P_2 = (1.3, -2.8)$  Round to three decimal places, if necessary.  
 A) 3.406                      B) 24                      C) 10.77                      D) 3.506

**Decide whether or not the points are the vertices of a right triangle.**

- 13)  $(-4, -1)$ ,  $(5, -1)$ ,  $(5, 4)$   
 A) Yes                      B) No
- 14)  $(8, 12)$ ,  $(10, 16)$ ,  $(12, 15)$   
 A) Yes                      B) No
- 15)  $(-5, -8)$ ,  $(1, -6)$ ,  $(0, -11)$   
 A) Yes                      B) No
- 16)  $(-2, 9)$ ,  $(4, 11)$ ,  $(10, 4)$   
 A) Yes                      B) No

**Solve the problem.**

- 17) Find all values of  $k$  so that the given points are  $\sqrt{29}$  units apart.  
 $(-5, 5)$ ,  $(k, 0)$   
 A) -3, -7                      B) -7                      C) 3, 7                      D) 7
- 18) Find the area of the right triangle ABC with  $A = (-2, 7)$ ,  $B = (7, -1)$ ,  $C = (3, 9)$ .  
 A) 29 square units                      B) 58 square units                      C)  $\frac{\sqrt{58}}{2}$  square units                      D)  $\frac{\sqrt{29}}{2}$  square units
- 19) Find all the points having an  $x$ -coordinate of 9 whose distance from the point  $(3, -2)$  is 10.  
 A)  $(9, 6)$ ,  $(9, -10)$                       B)  $(9, 2)$ ,  $(9, -4)$                       C)  $(9, -12)$ ,  $(9, 8)$                       D)  $(9, 13)$ ,  $(9, -7)$
- 20) A middle school's baseball playing field is a square, 60 feet on a side. How far is it directly from home plate to second base (the diagonal of the square)? If necessary, round to the nearest foot.  
 A) 85 feet                      B) 86 feet                      C) 84 feet                      D) 92 feet
- 21) A motorcycle and a car leave an intersection at the same time. The motorcycle heads north at an average speed of 20 miles per hour, while the car heads east at an average speed of 48 miles per hour. Find an expression for their distance apart in miles at the end of  $t$  hours.  
 A)  $52t$  miles                      B)  $t\sqrt{68}$  miles                      C)  $52\sqrt{t}$  miles                      D)  $2t\sqrt{13}$  miles
- 22) A rectangular city park has a jogging loop that goes along a length, width, and diagonal of the park. To the nearest yard, find the length of the jogging loop, if the length of the park is 125 yards and its width is 75 yards.  
 A) 346 yards                      B) 146 yards                      C) 345 yards                      D) 145 yards

23) Find the length of each side of the triangle determined by the three points  $P_1$ ,  $P_2$ , and  $P_3$ . State whether the triangle is an isosceles triangle, a right triangle, neither of these, or both.

$$P_1 = (-5, -4), P_2 = (-3, 4), P_3 = (0, -1)$$

A)  $d(P_1, P_2) = 2\sqrt{17}$ ;  $d(P_2, P_3) = \sqrt{34}$ ;  $d(P_1, P_3) = \sqrt{34}$

both

B)  $d(P_1, P_2) = 2\sqrt{17}$ ;  $d(P_2, P_3) = \sqrt{34}$ ;  $d(P_1, P_3) = \sqrt{34}$

isosceles triangle

C)  $d(P_1, P_2) = 2\sqrt{17}$ ;  $d(P_2, P_3) = \sqrt{34}$ ;  $d(P_1, P_3) = 5\sqrt{2}$

right triangle

D)  $d(P_1, P_2) = 2\sqrt{17}$ ;  $d(P_2, P_3) = \sqrt{34}$ ;  $d(P_1, P_3) = 5\sqrt{2}$

neither

## 2 Use the Midpoint Formula

**MULTIPLE CHOICE.** Choose the one alternative that best completes the statement or answers the question.

Find the midpoint of the line segment joining the points  $P_1$  and  $P_2$ .

1)  $P_1 = (3, 8)$ ;  $P_2 = (4, 1)$

A)  $(\frac{7}{2}, \frac{9}{2})$

B)  $(7, 9)$

C)  $(-1, 7)$

D)  $(\frac{9}{2}, \frac{7}{2})$

2)  $P_1 = (5, 4)$ ;  $P_2 = (4, -9)$

A)  $(\frac{9}{2}, -\frac{5}{2})$

B)  $(\frac{1}{2}, \frac{13}{2})$

C)  $(1, 13)$

D)  $(9, -5)$

3)  $P_1 = (7, 1)$ ;  $P_2 = (-16, -16)$

A)  $(-\frac{9}{2}, -\frac{15}{2})$

B)  $(\frac{23}{2}, \frac{17}{2})$

C)  $(-9, -15)$

D)  $(9, 15)$

4)  $P_1 = (-0.1, 0.7)$ ;  $P_2 = (-2.5, -1.5)$

A)  $(-1.3, -0.4)$

B)  $(-0.4, -1.3)$

C)  $(-1.2, -1.1)$

D)  $(-1.1, -1.2)$

5)  $P_1 = (b, 5)$ ;  $P_2 = (0, 9)$

A)  $(\frac{b}{2}, 7)$

B)  $(b, 14)$

C)  $(-\frac{b}{2}, 4)$

D)  $(b, 7)$

6)  $P_1 = (6x, 6)$ ;  $P_2 = (7x, 5)$

A)  $(\frac{13x}{2}, \frac{11}{2})$

B)  $(13x, 11)$

C)  $(x, 1)$

D)  $(\frac{11x}{2}, \frac{13}{2})$

**Solve the problem.**

7) If  $(-2, 4)$  is the endpoint of a line segment, and  $(2, 5)$  is its midpoint, find the other endpoint.

A)  $(6, 6)$

B)  $(6, 3)$

C)  $(-10, 2)$

D)  $(0, 12)$

8) If  $(1, 1)$  is the endpoint of a line segment, and  $(-4, -2)$  is its midpoint, find the other endpoint.

A)  $(-9, -5)$

B)  $(-9, 4)$

C)  $(11, 7)$

D)  $(-5, -9)$

9) If  $(8, 2)$  is the endpoint of a line segment, and  $(11, 1)$  is its midpoint, find the other endpoint.

A)  $(14, 0)$

B)  $(14, 3)$

C)  $(2, 4)$

D)  $(6, 8)$

- 10) If  $(-3, -2)$  is the endpoint of a line segment, and  $(-4, 0)$  is its midpoint, find the other endpoint.
- A)  $(-5, 2)$                       B)  $(-5, -4)$                       C)  $(-1, -6)$                       D)  $(1, -4)$
- 11) The medians of a triangle intersect at a point. The distance from the vertex to the point is exactly two-thirds of the distance from the vertex to the midpoint of the opposite side. Find the exact distance of that point from the vertex  $A(3, 4)$  of a triangle, given that the other two vertices are at  $(0, 0)$  and  $(8, 0)$ .
- A)  $\frac{2\sqrt{17}}{3}$                       B)  $\frac{\sqrt{17}}{3}$                       C) 2                      D)  $\frac{8}{3}$

### 3 Graph Equations by Plotting Points

**MULTIPLE CHOICE.** Choose the one alternative that best completes the statement or answers the question.

**Plot the point in the  $xy$ -plane. Tell in which quadrant or on what axis the point lies.**

1)  $(3, 5)$

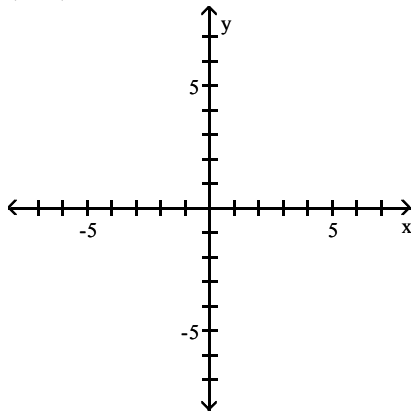

A)

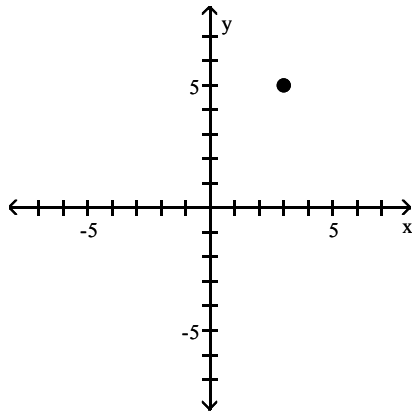

Quadrant I

C)

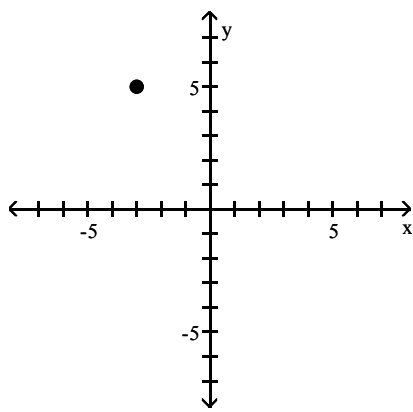

Quadrant II

B)

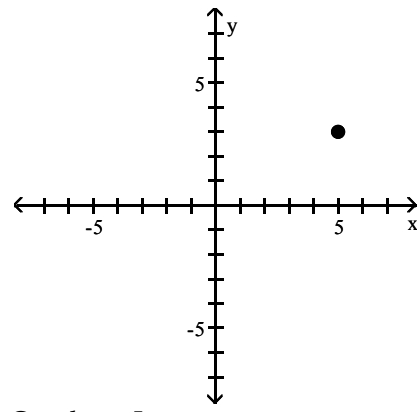

Quadrant I

D)

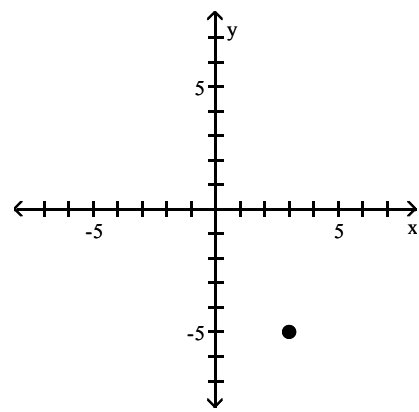

Quadrant IV

2)  $(-6, 1)$

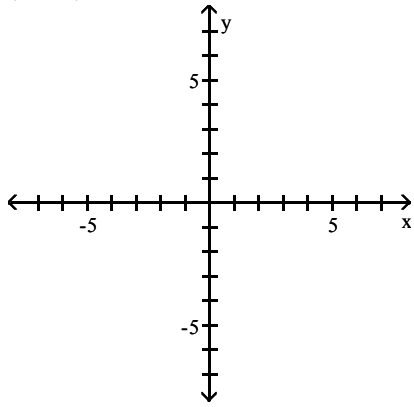

A)

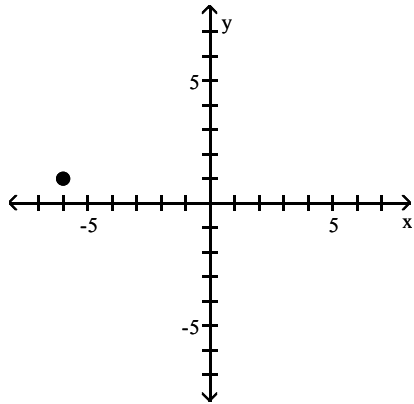

Quadrant II

C)

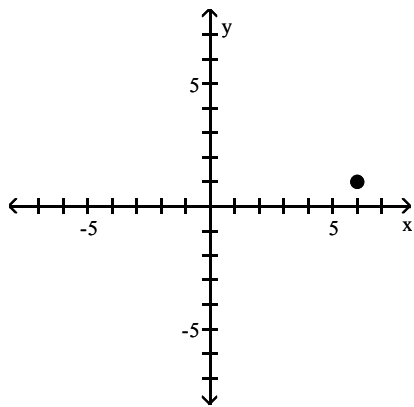

Quadrant I

B)

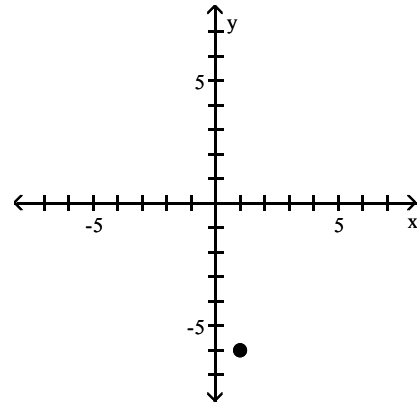

Quadrant IV

D)

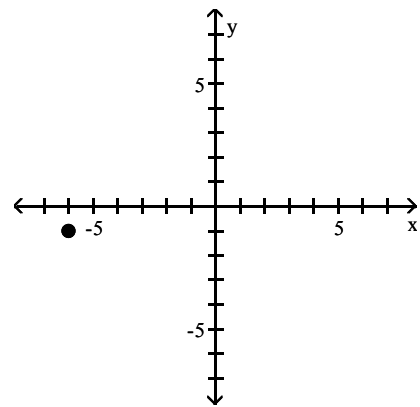

Quadrant III

3)  $(2, -4)$

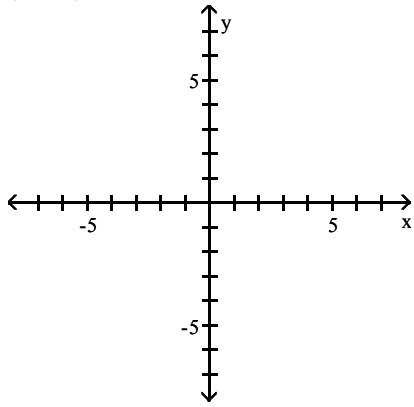

A)

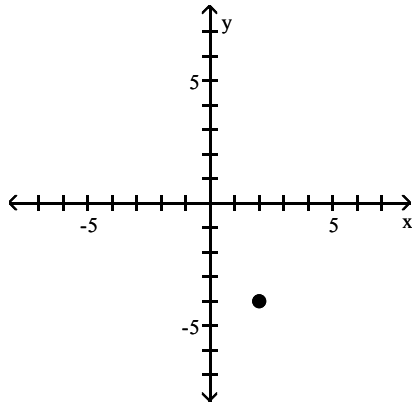

Quadrant IV

C)

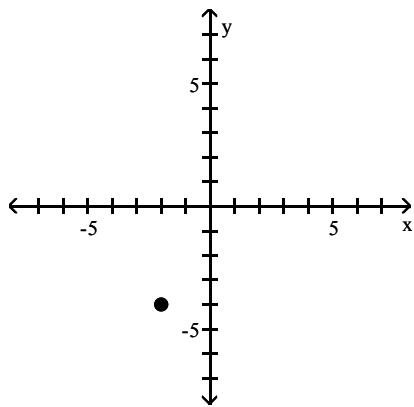

Quadrant III

B)

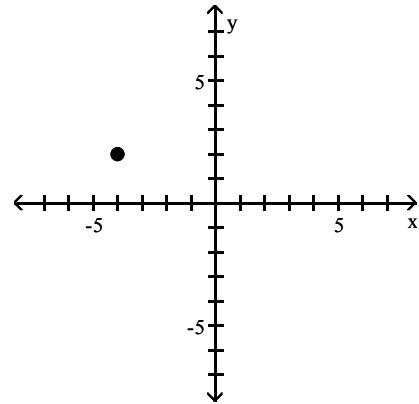

Quadrant II

D)

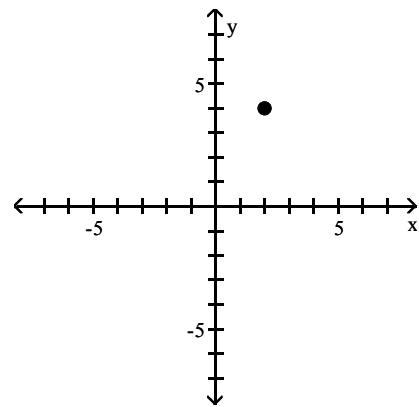

Quadrant I



4)  $(-5, -1)$

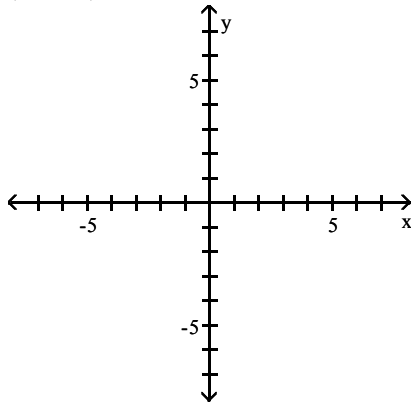

A)

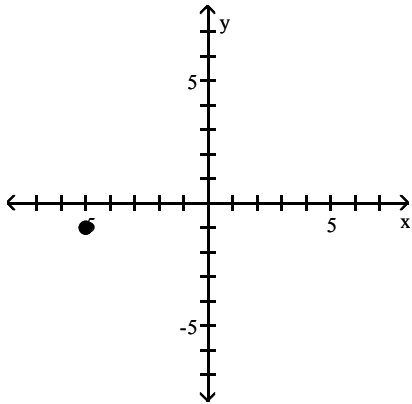

Quadrant III

C)

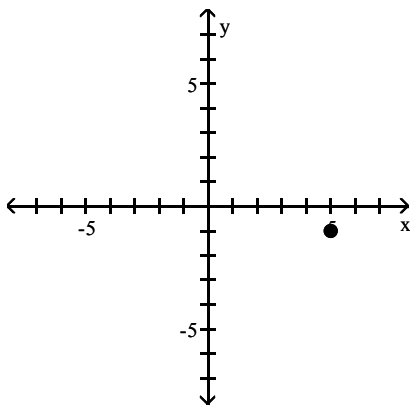

Quadrant IV

B)

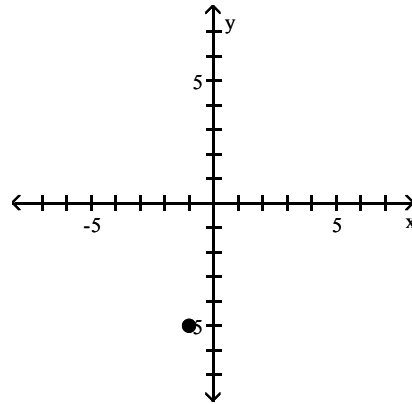

Quadrant III

D)

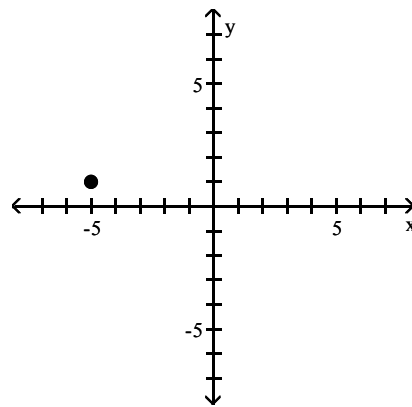

Quadrant II

5)  $(0, -6)$

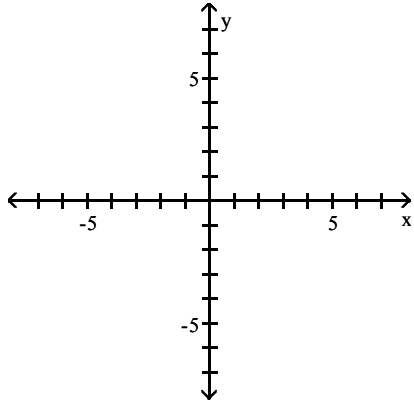

A)

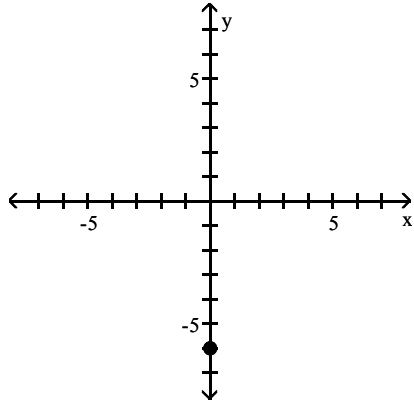

y-axis

C)

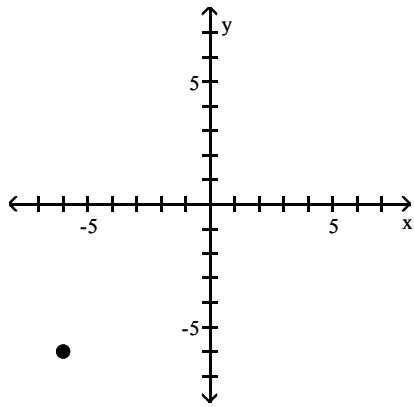

Quadrant II

B)

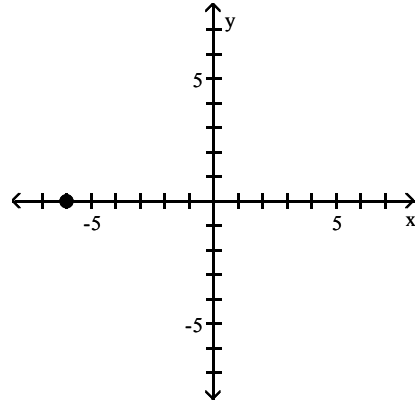

x-axis

D)

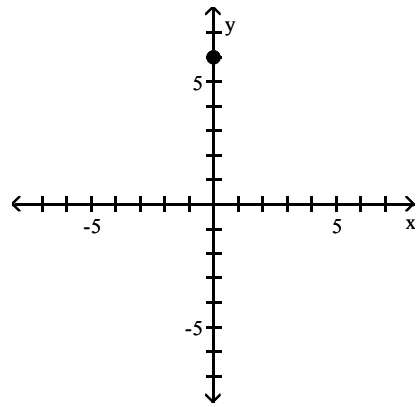

y-axis

6)  $(-5, 0)$

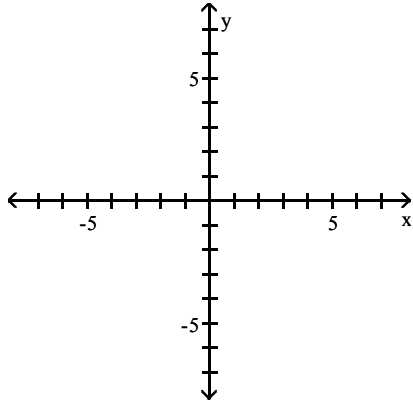

A)

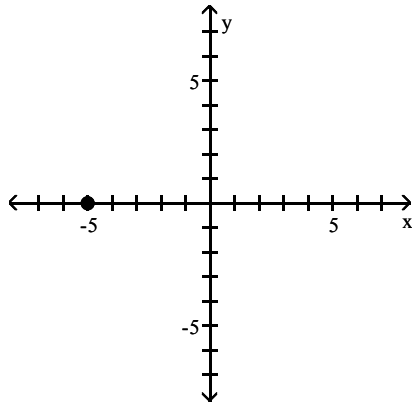

x-axis

C)

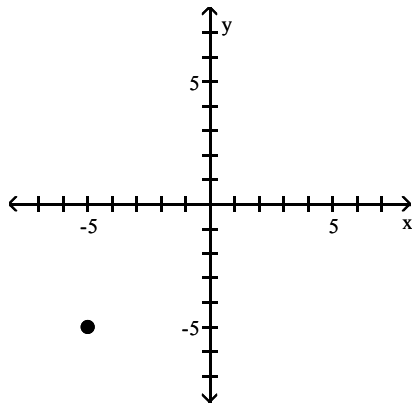

Quadrant II

B)

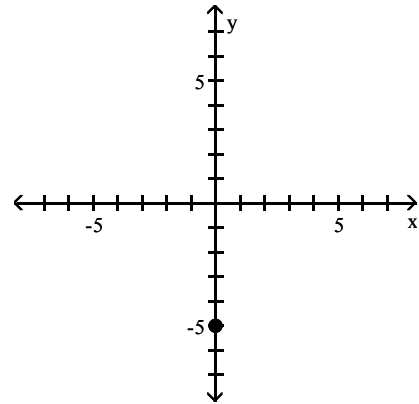

y-axis

D)

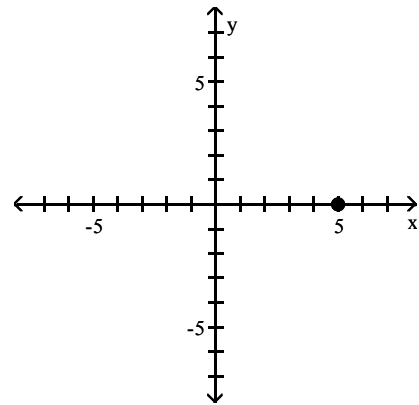

x-axis

**Determine whether the given point is on the graph of the equation.**

7) Equation:  $y = x^2 - \sqrt{x}$

Point:  $(0, 0)$

A) Yes

B) No

8) Equation:  $x^2 - y^2 = 64$

Point:  $(8, 8)$

A) No

B) Yes

Graph the equation by plotting points.

9)  $y = x - 2$

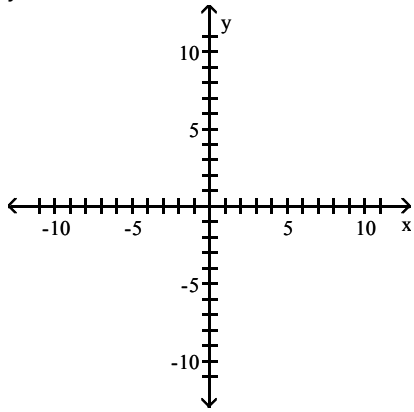

A)

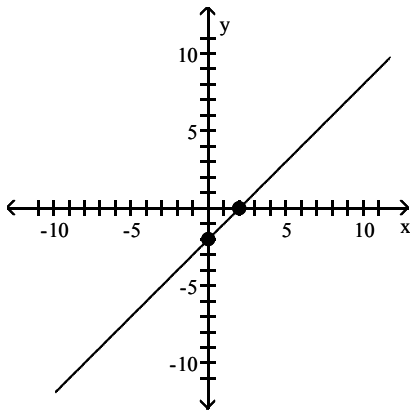

C)

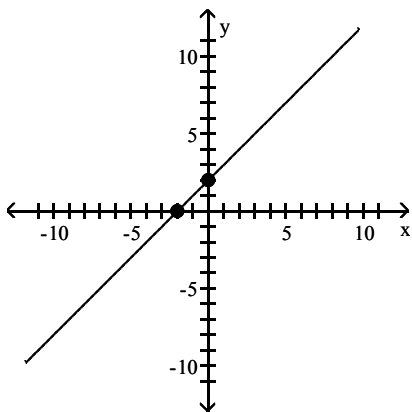

B)

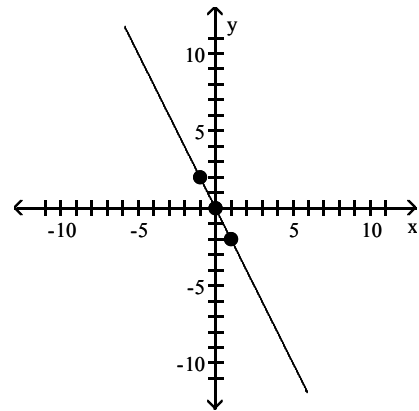

D)

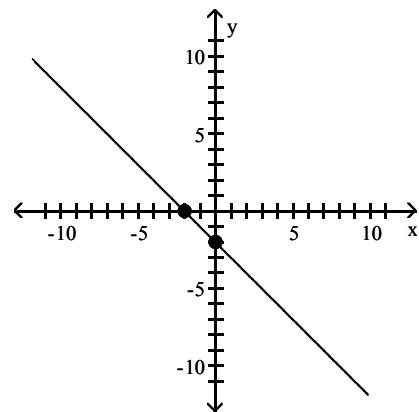

10)  $y = 2x + 8$

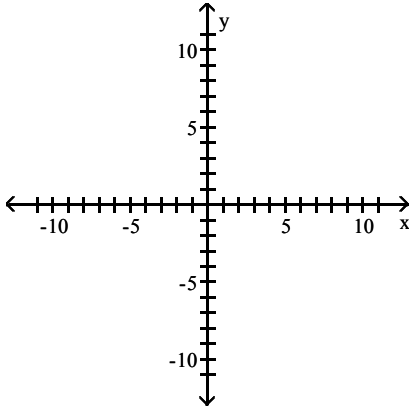

A)

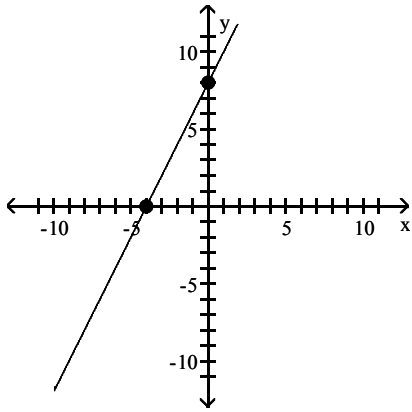

B)

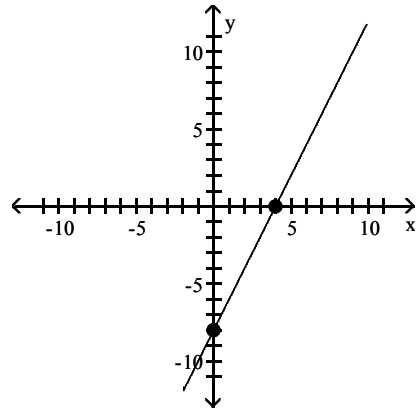

C)

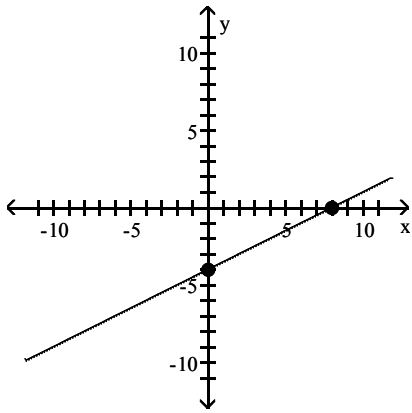

D)

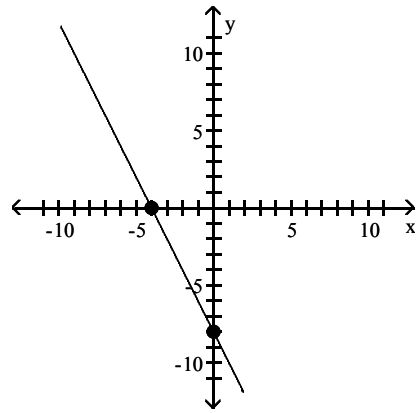

11)  $y = -x^2 + 1$

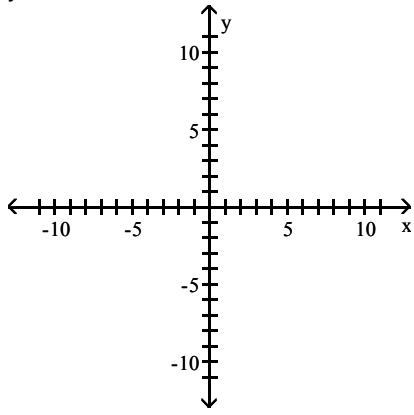

A)

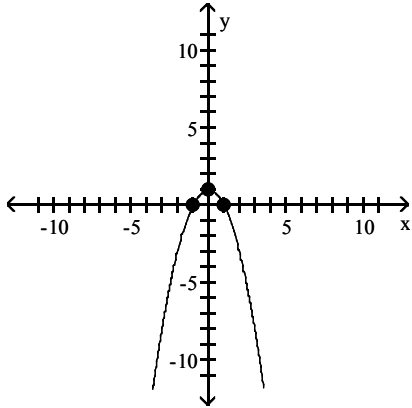

C)

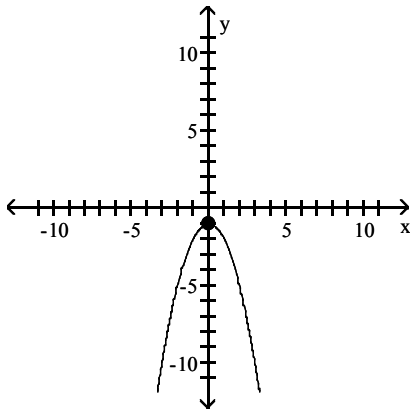

B)

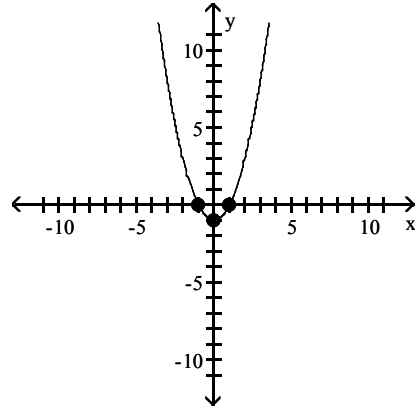

D)

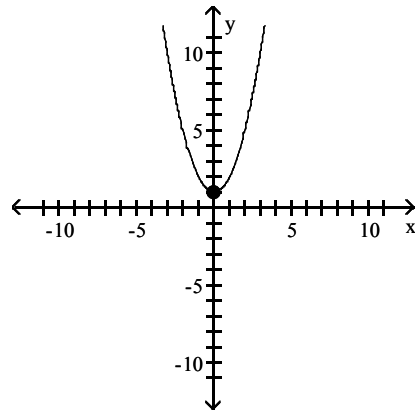

12)  $3x + 4y = 12$

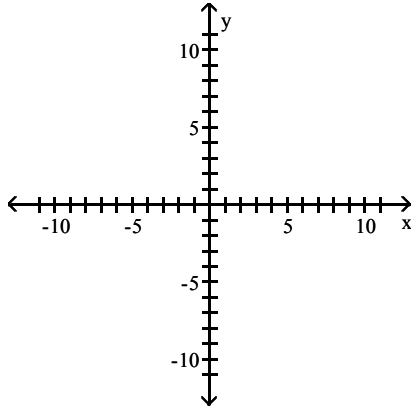

A)

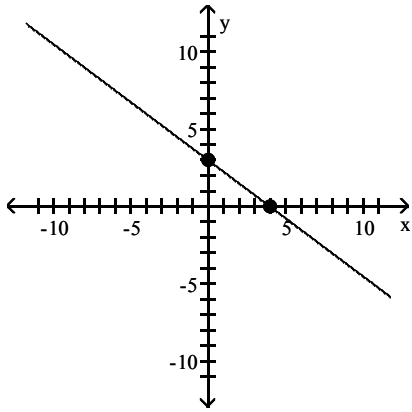

B)

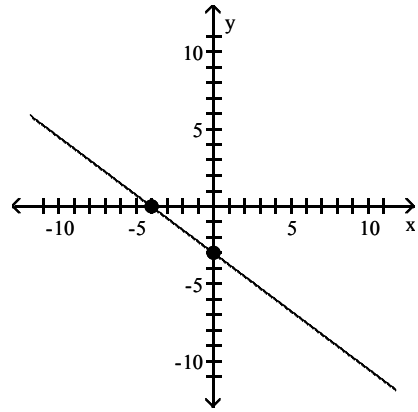

C)

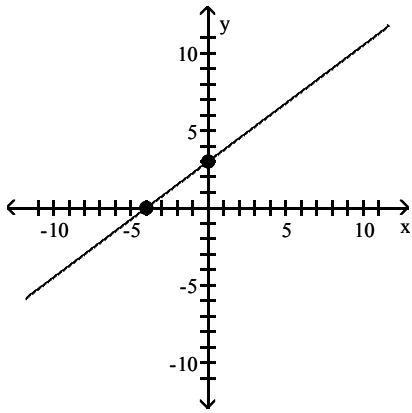

D)

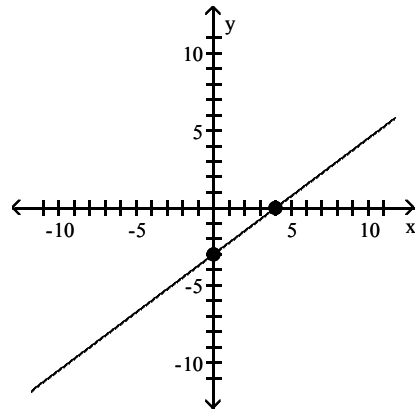

13)  $x^2 + 4y = 4$

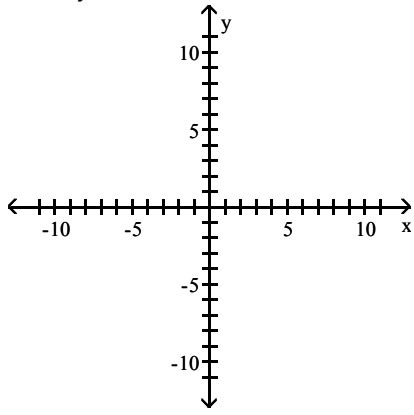

A)

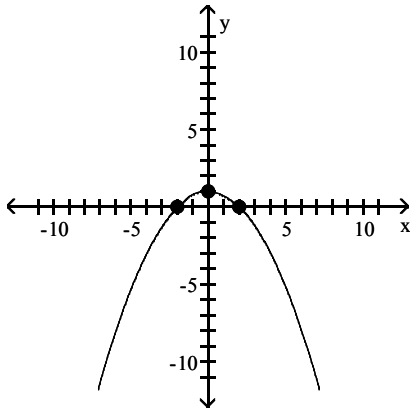

C)

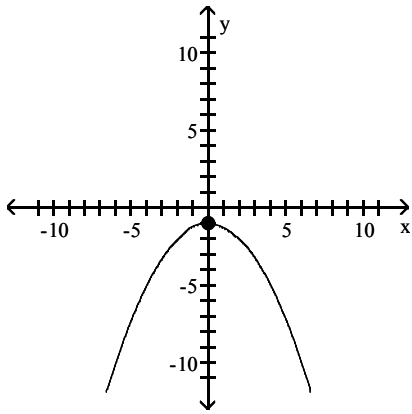

B)

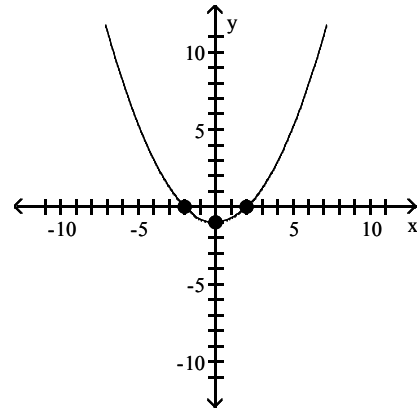

D)

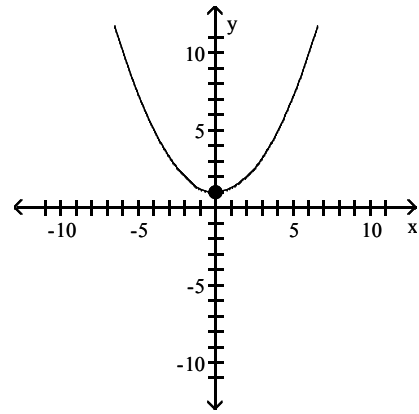



#### 4 Graph Equations Using a Graphing Utility

**MULTIPLE CHOICE.** Choose the one alternative that best completes the statement or answers the question.

Determine the coordinates of the point shown. Tell in which quadrant the point lies. Assume the coordinates are integers.

1)

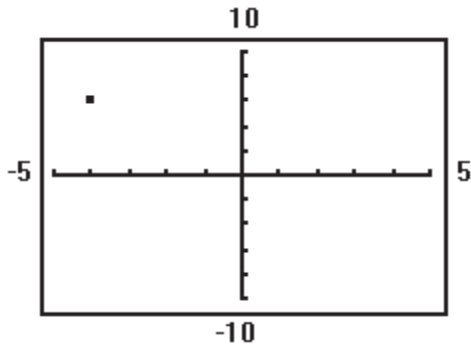

- A)  $(-4, 6)$ ; quadrant II
- C)  $(-4, 6)$ ; quadrant I

- B)  $(-4, 3)$ ; quadrant II
- D)  $(-4, 3)$ ; quadrant I

Select a setting so that each of the given points will lie in the viewing window.

2)  $(8, 3)$ ,  $(5, 1)$ ,  $(9, 19)$

A)

```

WINDOW
Xmin=0
Xmax=10
Xscl=1
Ymin=0
Ymax=20
Yscl=1
Xres=1
    
```

B)

```

WINDOW
Xmin=-5
Xmax=5
Xscl=1
Ymin=-4
Ymax=4
Yscl=1
Xres=1
    
```

C)

```

WINDOW
Xmin=-5
Xmax=5
Xscl=1
Ymin=-1
Ymax=10
Yscl=1
Xres=1
    
```

D)

```

WINDOW
Xmin=0
Xmax=20
Xscl=1
Ymin=0
Ymax=10
Yscl=1
Xres=1
    
```

Determine the viewing window used.

3)

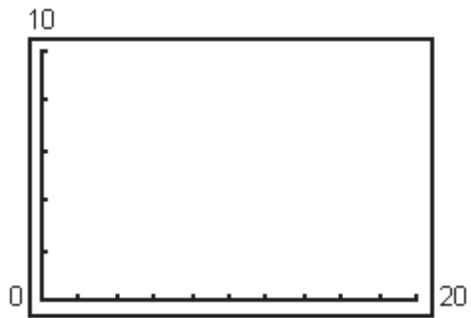

A)

```
WINDOW
Xmin=0
Xmax=20
Xscl=2
Ymin=0
Ymax=10
Yscl=2
Xres=1
```

B)

```
WINDOW
Xmin=0
Xmax=20
Xscl=1
Ymin=0
Ymax=10
Yscl=1
Xres=1
```

C)

```
WINDOW
Xmin=0
Xmax=10
Xscl=2
Ymin=0
Ymax=20
Yscl=2
Xres=1
```

D)

```
WINDOW
Xmin=0
Xmax=10
Xscl=1
Ymin=0
Ymax=20
Yscl=1
Xres=1
```

Graph the equation using a graphing utility.

4)  $y = 2x + 1$

A)

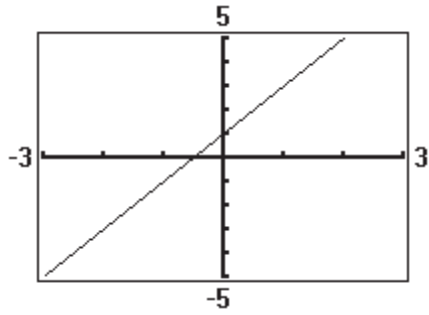

B)

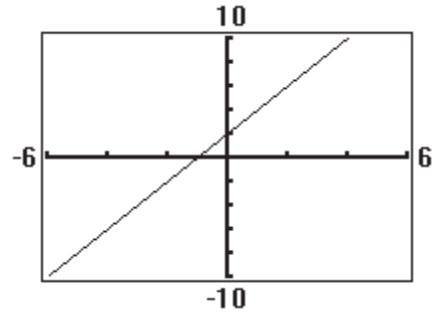

C)

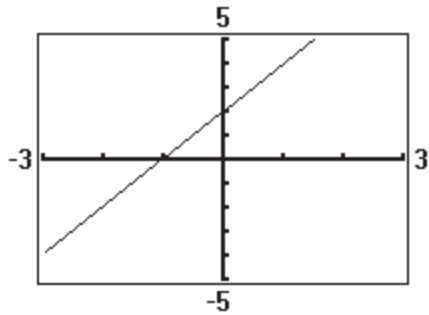

D)

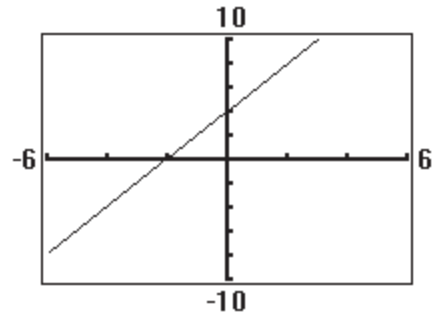

5)  $2x - 3y = 3$

A)

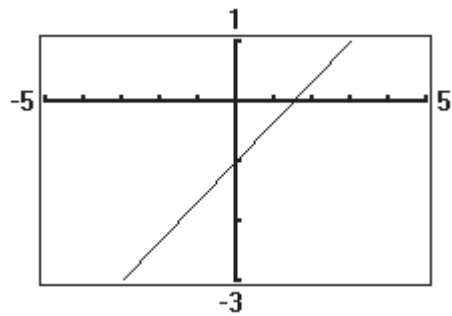

B)

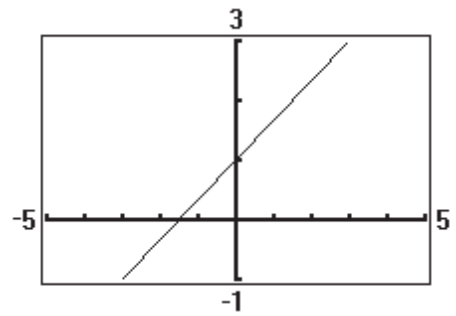

C)

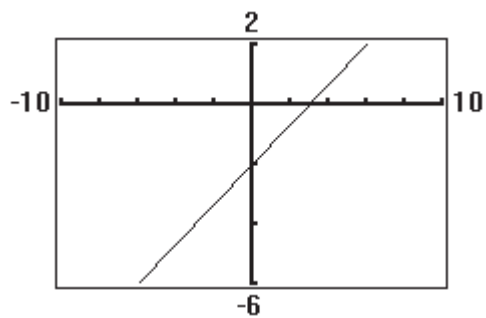

D)

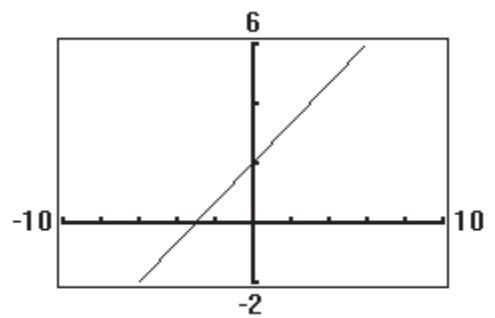

6)  $y = -2x^2 + 9$

A)

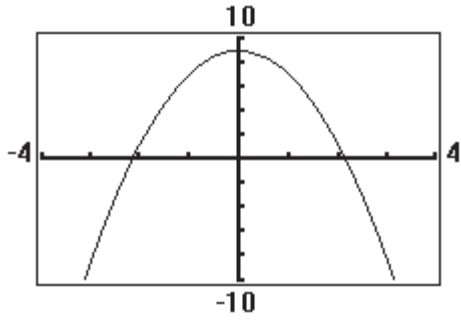

B)

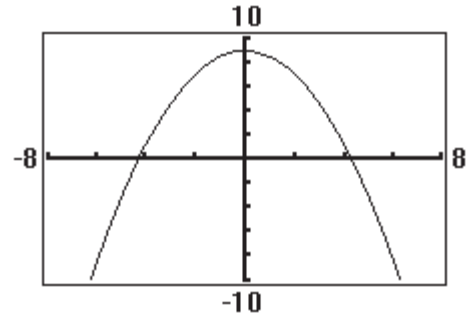

C)

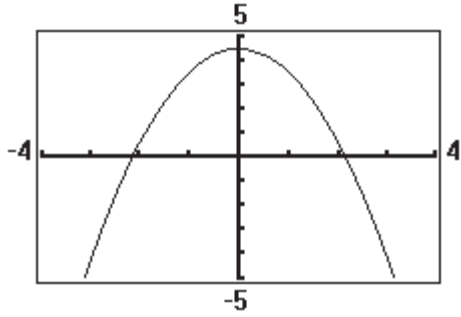

D)

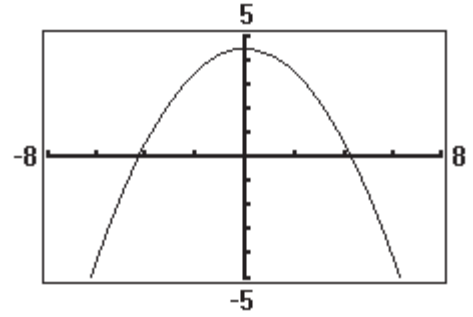

7)  $3x^2 - 2y = 56$

A)

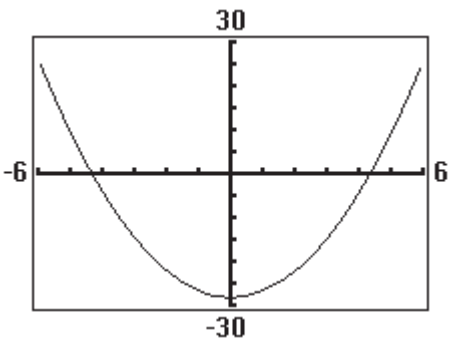

B)

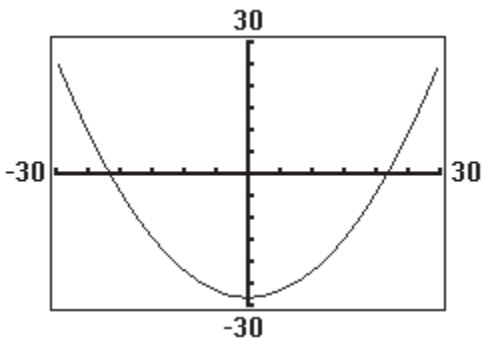

C)

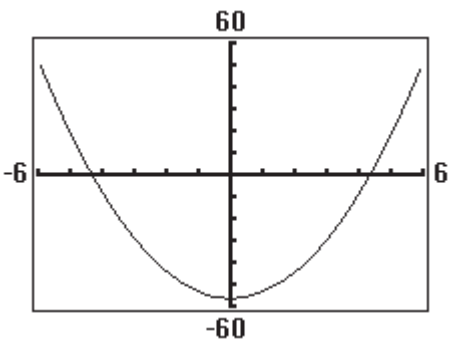

D)

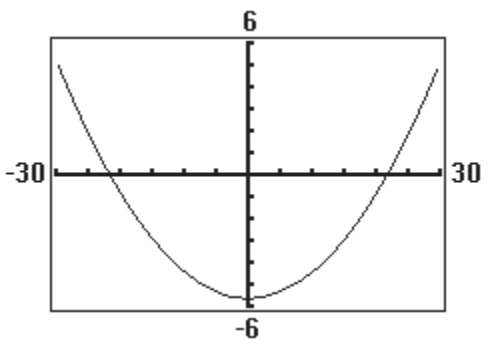

## 5 Use a Graphing Utility to Create Tables

**MULTIPLE CHOICE.** Choose the one alternative that best completes the statement or answers the question.

Use a graphing utility to create a table that displays the points on the graph of the given equation for  $x = -3, -2, -1, 0, 1, 2,$  and  $3$ .

1)  $y = 3x + 5$

A)

X	Y1	
-3	-4	
-2	-1	
-1	2	
0	5	
1	8	
2	11	
3	14	
$Y1 = 3X + 5$		

B)

X	Y1	
-3	14	
-2	11	
-1	8	
0	5	
1	2	
2	-1	
3	-4	
$Y1 = 3X + 5$		

C)

X	Y1	
-3	4	
-2	1	
-1	2	
0	5	
1	8	
2	11	
3	14	
$Y1 = 3X + 5$		

D)

X	Y1	
-3	-4	
-2	-1	
-1	-2	
0	5	
1	8	
2	11	
3	14	
$Y1 = 3X + 5$		

2)  $6x + 2y = 28$

A)

X	Y1	
-3	23	
-2	20	
-1	17	
0	14	
1	11	
2	8	
3	5	
$Y1 = -3X + 14$		

B)

X	Y1	
-3	5	
-2	8	
-1	11	
0	14	
1	17	
2	20	
3	23	
$Y1 = -3X + 14$		

C)

X	Y1	
-3	37	
-2	34	
-1	31	
0	28	
1	25	
2	22	
3	19	
$Y1 = -3X + 14$		

D)

X	Y1	
-3	19	
-2	22	
-1	25	
0	28	
1	31	
2	34	
3	37	
$Y1 = -3X + 14$		

3)  $y = -3x^2 + 10$

A)

X	Y1	
-3	-17	
-2	-2	
-1	7	
0	10	
1	7	
2	-2	
3	-17	
$Y1 = -3X^2 + 10$		

B)

X	Y1	
-3	17	
-2	2	
-1	-7	
0	-10	
1	-7	
2	2	
3	17	
$Y1 = -3X^2 + 10$		

C)

X	Y1	
-3	37	
-2	22	
-1	13	
0	10	
1	13	
2	22	
3	37	
$Y1 = -3X^2 + 10$		

D)

X	Y1	
-3	19	
-2	16	
-1	13	
0	10	
1	7	
2	4	
3	1	
$Y1 = -3X^2 + 10$		

4)  $4x^2 - 2y = 16$

A)

X	Y1	
-3	10	
-2	0	
-1	-6	
0	-8	
1	-6	
2	0	
3	10	
$Y1 = 2X^2 - 8$		

B)

X	Y1	
-3	-10	
-2	0	
-1	6	
0	8	
1	6	
2	0	
3	-10	
$Y1 = 2X^2 - 8$		

C)

X	Y1	
-3	26	
-2	16	
-1	10	
0	8	
1	10	
2	16	
3	26	
$Y1 = 2X^2 - 8$		

D)

X	Y1	
-3	-14	
-2	-12	
-1	-10	
0	-8	
1	-6	
2	-4	
3	-2	
$Y1 = 2X^2 - 8$		

## 6 Find Intercepts from a Graph

MULTIPLE CHOICE. Choose the one alternative that best completes the statement or answers the question.

List the intercepts of the graph.

1)

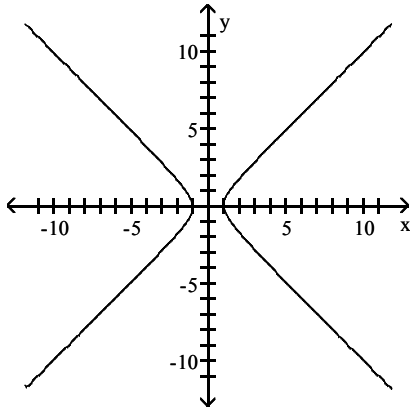

A)  $(-1, 0), (1, 0)$

B)  $(0, -1), (1, 0)$

C)  $(0, -1), (0, 1)$

D)  $(-1, 0), (0, 1)$

2)

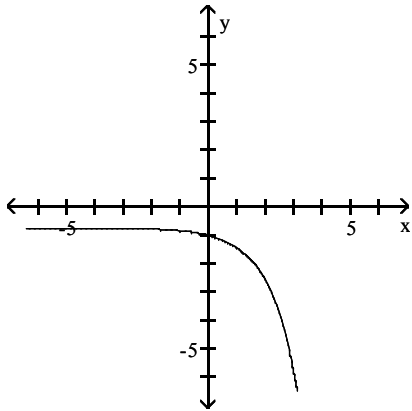

A)  $(0, -1)$

B)  $(0, 0)$

C)  $(-1, -1)$

D)  $(-1, 0)$

3)

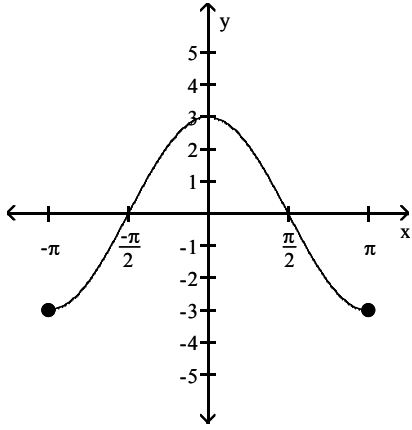

A)  $\left\{-\frac{\pi}{2}, 0\right\}, (0, 3), \left\{\frac{\pi}{2}, 0\right\}$   
 C)  $\left\{0, -\frac{\pi}{2}\right\}, (3, 0), \left\{0, \frac{\pi}{2}\right\}$

B)  $\left\{-\frac{\pi}{2}, 0\right\}, (3, 0), \left\{\frac{\pi}{2}, 0\right\}$   
 D)  $\left\{0, -\frac{\pi}{2}\right\}, (0, 3), \left\{0, \frac{\pi}{2}\right\}$

4)

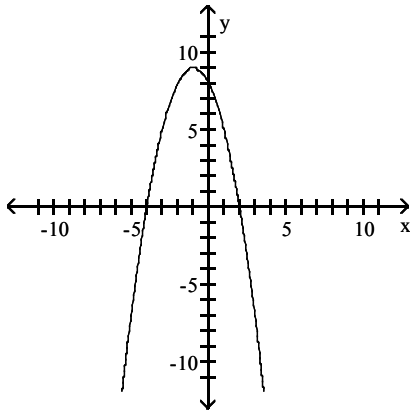

A)  $(-4, 0), (0, 8), (2, 0)$   
 C)  $(0, -4), (8, 0), (0, 2)$

B)  $(-4, 0), (0, 8), (0, 2)$   
 D)  $(0, -4), (0, 8), (2, 0)$

5)

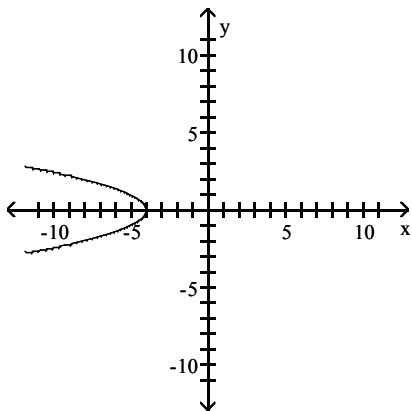

A)  $(-4, 0)$

B)  $(0, -4)$

C)  $(4, 0)$

D)  $(0, 4)$



6)

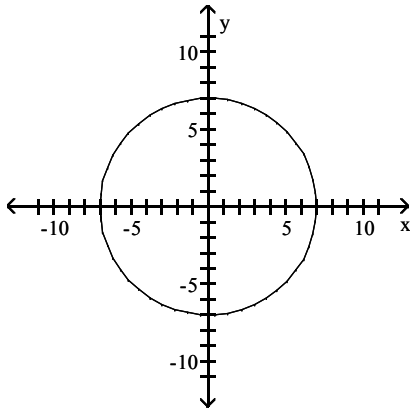

- A)  $(-7, 0), (0, -7), (0, 7), (7, 0)$   
 C)  $(-7, 0), (0, -7), (0, 0), (0, 7), (7, 0)$

- B)  $(-7, 0), (0, 7)$   
 D)  $(0, 7), (7, 0)$

7)

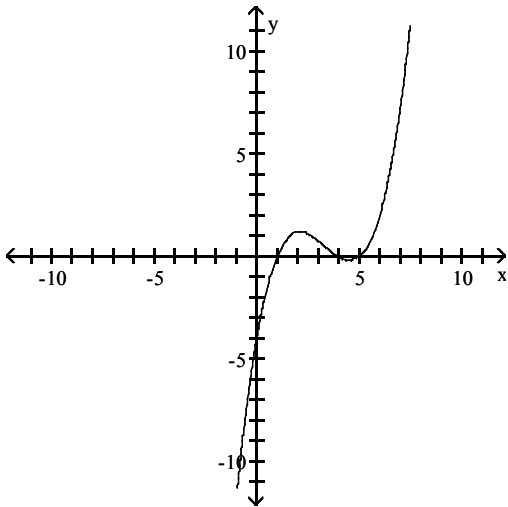

- A)  $(4, 0), (1, 0), (5, 0), (0, -4)$   
 C)  $(-4, 0), (1, 0), (-5, 0), (0, -4)$

- B)  $(-4, 0), (0, 4), (0, 1), (0, 5)$   
 D)  $(-4, 0), (0, -4), (0, 1), (0, -5)$

8)

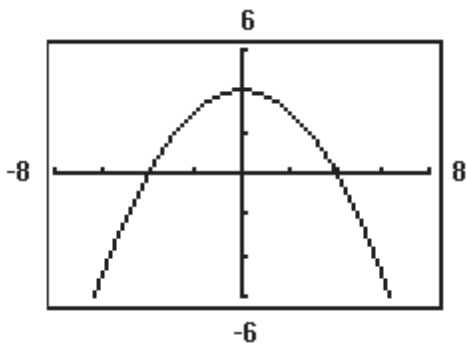

- A)  $(-4, 0), (0, 4), (4, 0)$

- B)  $(-2, 0), (0, 2), (2, 0)$

- C)  $(-2, 0), (0, 4), (2, 0)$

- D)  $(-2, 0), (2, 0)$

## 7 Use a Graphing Utility to Approximate Intercepts

**MULTIPLE CHOICE.** Choose the one alternative that best completes the statement or answers the question.

**Graph the equation using a graphing utility. Use a graphing utility to approximate the intercepts rounded to two decimal places, if necessary. Use the TABLE feature to help establish the viewing window.**

1)  $y = -2x + 15$

A) (0, 15), (7.5, 0)

C) (0, -15), (7.5, 0)

B) (0, 15), (-7.5, 0)

D) (0, 15), (-7.5, 0), (7.5, 0)

2)  $y = -4x + 15$

A) (0, 15), (3.75, 0)

B) (0, 3.75), (15, 0)

C) (0, 15), (-3.75, 0)

D) (0, -3.75), (15, 0)

3)  $y = 3x^2 - 19$

A) (0, -19), (-2.52, 0), (2.52, 0)

C) (0, 19), (-2.52, 0), (2.52, 0)

B) (0, -19), (2.52, 0)

D) (0, -19), (-2.51, 0), (2.51, 0)

4)  $y = 5x^2 - 13$

A) (0, -13), (1.61, 0), (-1.61, 0)

C) (0, -13), (2.60, 0), (-2.60, 0)

B) (0, 1.61), (0, -1.61), (-13, 0)

D) (0, 2.60), (0, -2.60), (-13, 0)

5)  $3x - 4y = 56$

A) (0, -14), (18.67, 0)

C) (0, -14), (-18.67, 0), (18.67, 0)

B) (0, -14), (18.66, 0)

D) (0, 14), (18.67, 0)

6)  $6x - 5y = 67$

A) (0, -13.40), (11.17, 0)

C) (0, 13.40), (-11.17, 0)

B) (0, 11.17), (-13.40, 0)

D) (0, -13.41), (11.18, 0)

7)  $3x^2 - 5y = 34$

A) (0, -6.8), (-3.37, 0), (3.37, 0)

C) (0, 6.8), (-3.37, 0), (3.37, 0)

B) (0, -6.8), (-3.36, 0), (3.36, 0)

D) (0, -6.8), (3.37, 0)

8)  $4x^2 - 5y = 68$

A) (0, -13.60), (4.12, 0), (-4.12, 0)

C) (0, -13.59), (4.13, 0), (-4.13, 0)

B) (0, 4.12), (0, -4.12), (-13.60, 0)

D) (0, 13.60), (4.12, 0), (-4.12, 0)

## 1.2 Solving Equations Using a Graphing Utility; Linear and Rational Equations

### 1 Solve Equations Using a Graphing Utility

**MULTIPLE CHOICE.** Choose the one alternative that best completes the statement or answers the question.

**Use a graphing utility to approximate the real solutions, if any, of the equation rounded to two decimal places.**

1)  $x^3 - 6x + 3 = 0$

A) {2.15, 0.52, -2.67}

B) {-0.48}

C) {2.67, -0.52, -2.15}

D) no solution

2)  $x^4 - 3x^2 + 4x + 15 = 0$

A) {-0.84, -1.93}

B) {2.11, -2.60}

C) {3.94, -1.27}

D) no solution

3)  $2x^4 - 5x^2 + 7x = 14$

A) {-2.31, 1.69}

B) {-2.31, 1.70}

C) {-2.30, 1.69}

D) {-2.32, 1.70}

$$4) x^4 - 5x^3 + 6x - 2 = 0$$

A) {4.75, 1, 0.38, -1.13}

C) {4.71, 1.44, -0.38, -0.77}

B) {0.31, -5.23}

D) no solution

$$5) -x^4 + 3x^3 + \frac{4}{3}x^2 = \frac{9}{2}x + 2$$

A) {2.82, 1.61, -0.46, -0.97}

C) {1.09, -0.44}

B) {-3.34}

D) no solution

## 2 Solve Linear Equations

**MULTIPLE CHOICE.** Choose the one alternative that best completes the statement or answers the question.

**Solve the equation.**

1)  $4x = -24$

A) {-6}

B) {6}

C) {4}

D) {-4}

2)  $9x = 12$

A)  $\left\{\frac{4}{3}\right\}$

B)  $\left\{-\frac{4}{3}\right\}$

C)  $\left\{\frac{3}{4}\right\}$

D)  $\left\{-\frac{3}{4}\right\}$

3)  $2x + 6 = 0$

A) {-3}

B) {3}

C) {2}

D) {-2}

4)  $5x - 10 = 0$

A) {2}

B) {-2}

C)  $\left\{\frac{1}{2}\right\}$

D)  $\left\{-\frac{1}{2}\right\}$

5)  $7x + 2 = 0$

A)  $\left\{-\frac{2}{7}\right\}$

B)  $\left\{\frac{2}{7}\right\}$

C)  $\left\{\frac{7}{2}\right\}$

D)  $\left\{-\frac{7}{2}\right\}$

6)  $\frac{1}{2}x = -\frac{5}{9}$

A)  $\left\{-\frac{10}{9}\right\}$

B)  $\left\{-\frac{9}{10}\right\}$

C)  $\left\{\frac{10}{9}\right\}$

D)  $\left\{\frac{10}{3}\right\}$

7)  $13x = -13 + 12x$

A) {-13}

B) {13}

C) {-12}

D) {-1}

8)  $10x - 18 = 4x + 30$

A) {8}

B) {-8}

C) {5}

D) {-5}

9)  $-3x - 49 = 4x + 7$

A) {-8}

B) {8}

C) {-7}

D) {7}

10)  $35 - 2x = -14 + 5x$

A) {7}

B) {-7}

C) {5}

D) {-5}

11)  $7x - (2x - 1) = 2$

A)  $\left\{\frac{1}{5}\right\}$

B)  $\left\{\frac{1}{9}\right\}$

C)  $\left\{-\frac{1}{5}\right\}$

D)  $\left\{-\frac{1}{9}\right\}$

$$12) 3(4x - 1) = 12$$

$$A) \left\{ \frac{5}{4} \right\}$$

$$B) \left\{ \frac{3}{4} \right\}$$

$$C) \left\{ \frac{13}{12} \right\}$$

$$D) \left\{ \frac{11}{12} \right\}$$

$$13) 14(5x - 2) = 9x - 7$$

$$A) \left\{ \frac{21}{61} \right\}$$

$$B) \left\{ \frac{35}{61} \right\}$$

$$C) \left\{ -\frac{21}{61} \right\}$$

$$D) \left\{ \frac{21}{79} \right\}$$

$$14) 6(x + 5) = 7[x - (3 - x)]$$

$$A) \left\{ \frac{51}{8} \right\}$$

$$B) \left\{ -\frac{15}{4} \right\}$$

$$C) \left\{ \frac{15}{4} \right\}$$

$$D) \left\{ -\frac{51}{8} \right\}$$

$$15) 3(x + 2) = 4(x - 8)$$

$$A) \{38\}$$

$$B) \{-38\}$$

$$C) \{-26\}$$

$$D) \{4\}$$

$$16) 4(2x - 2) = 7(x + 5)$$

$$A) \{43\}$$

$$B) \{-27\}$$

$$C) \{-43\}$$

$$D) \{31\}$$

$$17) 3(x + 4) = (3x + 12)$$

$$A) \{24\}$$

$$B) \{0\}$$

$$C) \text{all real numbers}$$

$$D) \text{no solution}$$

$$18) -5x - 6 - 7(x + 1) = 7x + 2$$

$$A) \left\{ -\frac{15}{19} \right\}$$

$$B) \left\{ -\frac{5}{8} \right\}$$

$$C) \left\{ \frac{3}{10} \right\}$$

$$D) \{7\}$$

$$19) -9x + 6 + 7x = -2x + 11$$

$$A) \{5\}$$

$$B) \{-6\}$$

$$C) \text{all real numbers}$$

$$D) \text{no solution}$$

$$20) \frac{x}{2} - 4 = 1$$

$$A) \{10\}$$

$$B) \{-10\}$$

$$C) \{6\}$$

$$D) \{-6\}$$

$$21) \frac{x}{2} - \frac{1}{2} = -3$$

$$A) \{-5\}$$

$$B) \{5\}$$

$$C) \{-7\}$$

$$D) \{7\}$$

$$22) \frac{2x}{5} = 2 + \frac{x}{3}$$

$$A) \{30\}$$

$$B) \{-30\}$$

$$C) \{60\}$$

$$D) \{-60\}$$

$$23) \frac{x}{3} + 1 = \frac{x}{4} + 3$$

$$A) \{24\}$$

$$B) \{-24\}$$

$$C) \left\{ \frac{1}{6} \right\}$$

$$D) \left\{ -\frac{1}{6} \right\}$$

$$24) \frac{1}{5} - \frac{x}{2} = \frac{17}{10}$$

$$A) \{-3\}$$

$$B) \{3\}$$

$$C) \left\{ -\frac{15}{2} \right\}$$

$$D) \left\{ \frac{15}{2} \right\}$$

25)  $-9.6x + 1.7 = -83 - 1.9x$

A) {11}

B) {-92}

C) {8.8}

D) {9}

26)  $\frac{-3x + 5}{7} + \frac{3}{7} = -\frac{7x}{3}$

A)  $\left\{-\frac{3}{5}\right\}$

B)  $\left\{-\frac{3}{20}\right\}$

C)  $\left\{\frac{3}{20}\right\}$

D)  $\left\{\frac{12}{29}\right\}$

27)  $(x + 2)(x - 1) = (x + 1)^2$

A) {-3}

B) {-2}

C)  $\left\{\frac{3}{2}\right\}$

D) {3}

28)  $x(3x - 4) = (3x + 1)(x - 2)$

A) {-2}

B) {-1}

C) {2}

D) {5}

29)  $x(1 + 3x) = (3x - 1)(x - 3)$

A)  $\left\{\frac{3}{11}\right\}$

B)  $\left\{-\frac{3}{11}\right\}$

C)  $\left\{\frac{3}{121}\right\}$

D)  $\left\{-\frac{3}{121}\right\}$

30)  $x(x^2 + 4) = 9 + x^3$

A)  $\left\{\frac{9}{4}\right\}$

B) {4}

C) {9}

D)  $\left\{\frac{4}{9}\right\}$

**Solve the problem.**

31) If (a, 3) is a point on the graph of  $y = 2x - 5$ , what is a?

A) 4

B) 1

C) -1

D) -4

32) If (3, b) is a point on the graph of  $3x - 2y = 17$ , what is b?

A) -4

B) 4

C)  $\frac{23}{3}$

D)  $\frac{11}{3}$

**Solve the equation. The letters a, b, and c are constants.**

33)  $ax - b = c, a \neq 0$

A)  $x = \frac{b + c}{a}$

B)  $x = \frac{b - c}{a}$

C)  $x = \frac{c - b}{a}$

D)  $x = -\frac{b + c}{a}$

34)  $\frac{x}{a} + \frac{x}{b} = c, a \neq 0, b \neq 0, a \neq -b$

A)  $x = \frac{abc}{a + b}$

B)  $x = abc$

C)  $x = \frac{c}{ab}$

D)  $x = \frac{a + b}{abc}$

### 3 Solve Rational Equations

**MULTIPLE CHOICE. Choose the one alternative that best completes the statement or answers the question.**

**Solve the equation.**

1)  $1 - \frac{3}{4x} = 2$

A)  $\left\{-\frac{3}{4}\right\}$

B)  $\left\{\frac{3}{4}\right\}$

C)  $\left\{-\frac{12}{7}\right\}$

D)  $\left\{-\frac{7}{4}\right\}$

$$2) \frac{5}{x} + \frac{2}{5} = \frac{7}{x}$$

A) {5}

B) {-5}

C) {2}

D) {-2}

$$3) \frac{-8}{x} + \frac{5}{x} = 5$$

A)  $\left\{-\frac{3}{5}\right\}$

B)  $\left\{-\frac{5}{3}\right\}$

C)  $\left\{\frac{3}{5}\right\}$

D)  $\left\{\frac{5}{3}\right\}$

$$4) \frac{3}{x+5} + \frac{2}{2x+1} = \frac{4}{x-2}$$

A)  $\left\{-\frac{46}{47}\right\}$

B)  $\left\{\frac{46}{47}\right\}$

C)  $\left\{-\frac{47}{46}\right\}$

D)  $\left\{\frac{47}{46}\right\}$

$$5) \frac{5-x}{x} + \frac{3}{4} = \frac{7}{x}$$

A) {-8}

B)  $\left\{-\frac{8}{7}\right\}$

C) {8}

D) {-4}

$$6) \frac{x}{x-9} - 4 = \frac{9}{x-9}$$

A) {9, -9}

B) {9}

C) {-9}

D) no solution

$$7) \frac{x}{2x+2} = \frac{2x-3}{x+1} - \frac{2x}{4x+4}$$

A) {3}

B)  $\left\{\frac{3}{2}\right\}$

C) {-3}

D) no solution

$$8) \frac{1}{x} + \frac{1}{x+6} = \frac{x+7}{x+6}$$

A) {1}

B) {-6}

C) {-1}

D) {6}

$$9) \frac{6}{2x-3} = \frac{4}{2x+5}$$

A)  $\left\{-\frac{21}{2}\right\}$

B)  $\left\{\frac{21}{2}\right\}$

C)  $\left\{-\frac{2}{21}\right\}$

D)  $\left\{\frac{2}{21}\right\}$

$$10) \frac{2x}{x^2-4} = \frac{1}{x^2-4} - \frac{4}{x+2}$$

A)  $\left\{\frac{3}{2}\right\}$

B)  $\left\{-\frac{7}{6}\right\}$

C)  $\left\{\frac{7}{2}\right\}$

D)  $\left\{-\frac{3}{8}\right\}$

$$11) \frac{x-2}{x-5} = \frac{x+6}{x-7}$$

A)  $\left\{\frac{22}{5}\right\}$

B)  $\left\{-\frac{15}{7}\right\}$

C) {-4}

D)  $\left\{\frac{8}{5}\right\}$

$$12) \frac{10x + 5}{2x - 9} = \frac{15x - 6}{3x - 5}$$

$$A) \left\{ \frac{79}{112} \right\}$$

$$B) \left\{ -\frac{79}{182} \right\}$$

$$C) \left\{ \frac{29}{112} \right\}$$

$$D) \left\{ -\frac{29}{182} \right\}$$

$$13) \frac{6}{5x} - \frac{1}{x+1} = \frac{3}{x(2x+2)}$$

$$A) \left\{ \frac{3}{2} \right\}$$

$$B) \{3\}$$

$$C) \left\{ \frac{3}{10} \right\}$$

D) no solution

$$14) \frac{6}{x+3} - \frac{2}{x-3} = \frac{8}{x^2 - 9}$$

$$A) \{8\}$$

$$B) \{-8\}$$

$$C) \{\sqrt{13}\}$$

$$D) \{32\}$$

$$15) \frac{-4}{x-6} = \frac{-2}{x-12} - \frac{-24}{x^2 - 18x + 72}$$

$$A) \{6, 12\}$$

$$B) \{6\}$$

$$C) \{12\}$$

D) no solution

Solve the equation. The letters a, b, and c are constants.

$$16) \frac{a}{x} + \frac{b}{x} = c, c \neq 0$$

$$A) x = \frac{a+b}{c}$$

$$B) x = \frac{c}{a+b}$$

$$C) x = \frac{ab}{c}$$

$$D) x = \frac{c}{ab}$$

#### 4 Solve Problems That Can Be Modeled by Linear Equations

**MULTIPLE CHOICE.** Choose the one alternative that best completes the statement or answers the question.

Solve the formula for the indicated variable.

1)  $PV = nRT$  for R

$$A) R = \frac{PV}{nT}$$

$$B) R = \frac{PV}{T}$$

$$C) R = \frac{nPV}{T}$$

$$D) R = \frac{PVT}{n}$$

2)  $I = PRT$  for P

$$A) P = \frac{I}{RT}$$

$$B) P = \frac{IR}{T}$$

$$C) P = \frac{IT}{R}$$

$$D) P = IRT$$

3)  $S = 2\pi rh + 2\pi r^2$  for h

$$A) h = \frac{S - 2\pi r^2}{2\pi r}$$

$$B) h = S - r$$

$$C) h = \frac{S}{2\pi r} - 1$$

$$D) h = 2\pi(S - r)$$

4)  $F = \frac{9}{5}C + 32$  for C

$$A) C = \frac{5}{9}(F - 32)$$

$$B) C = \frac{9}{5}(F - 32)$$

$$C) C = \frac{F - 32}{9}$$

$$D) C = \frac{5}{F - 32}$$

5)  $A = P(1 + rt)$  for t

$$A) t = \frac{A - P}{rP}$$

$$B) t = \frac{A + P}{rP}$$

$$C) t = -\frac{A + P}{rP}$$

$$D) t = \frac{P - A}{rP}$$

6)  $A = \frac{1}{2}h(b_1 + b_2)$  for  $b_1$

A)  $b_1 = \frac{2A}{h} - b_2$

B)  $b_1 = \frac{2A}{h} + b_2$

C)  $b_1 = \frac{2A - b_2}{h}$

D)  $b_1 = \frac{2A + b_2}{h}$

7)  $P - \frac{7Q}{3} = \frac{P + 5}{2} + 1$  for  $P$

A)  $P = \frac{21 + 14Q}{3}$

B)  $P = \frac{21 - 14Q}{3}$

C)  $P = \frac{9 - 14Q}{3}$

D)  $P = \frac{9 + 14Q}{3}$

**Solve the problem.**

8) Mary and her brother John collect foreign coins. Mary has three times the number of coins that John has. Together they have 140 foreign coins. Find how many coins Mary has.

A) 105 coins

B) 35 coins

C) 21 coins

D) 98 coins

9) Center City East Parking Garage has a capacity of 259 cars more than Center City West Parking Garage. If the combined capacity for the two garages is 1225 cars, find the capacity for each garage.

A) Center City East: 742 cars

B) Center City East: 483 cars

Center City West: 483 cars

Center City West: 742 cars

C) Center City East: 752 cars

D) Center City East: 473 cars

Center City West: 473 cars

Center City West: 752 cars

10) During an intramural basketball game, Team A scored 13 fewer points than Team B. Together, both teams scored a total of 145 points. How many points did Team A score during the game?

A) 66 points

B) 79 points

C) 67 points

D) 72 points

11) An inheritance of \$1,060,000 is to be divided among Chris, Kelly, and Julie in the following manner: Kelly is to receive  $\frac{3}{5}$  of what Chris gets, while Julie gets  $\frac{1}{6}$  of what Chris gets. How much does Kelly receive?

A) \$360,000

B) \$600,000

C) \$100,000

D) \$120,000

12) An auto repair shop charged a customer \$541 to repair a car. The bill listed \$91 for parts and the remainder for labor. If the cost of labor is \$45 per hour, how many hours of labor did it take to repair the car?

A) 10 hr

B) 9 hr

C) 11 hr

D) 10.5 hr

13) Going into the final exam, which will count as three tests, Jerome has test scores of 61, 72, 59, 75, and 77. What score does Jerome need on the final in order to earn a C, which requires an average of 70?

A) 72

B) 82

C) 74

D) 76

14) Going into the final exam, which will count as two tests, Emily has test scores of 76, 83, 73, 64, and 92. What score does Emily need on the final in order to have an average score of 80?

A) 86

B) 46

C) 92

D) 66

15) After a 17% price reduction, a boat sold for \$29,050. What was the boat's price before the reduction? (Round to the nearest cent, if necessary.)

A) \$35,000

B) \$4938.50

C) \$170,882.35

D) \$33,988.50

16) Inclusive of a 7.2% sales tax, a diamond ring sold for \$1715.20. Find the price of the ring before the tax was added. (Round to the nearest cent, if necessary.)

A) \$1600

B) \$1838.69

C) \$1591.71

D) \$123.49



- 17) It costs \$21 per hour plus a flat fee of \$23 for a plumber to make a house call. After writing an equation for this situation, suppose the total cost to have a plumber come to a house is \$191. How many hours did the plumber work?
- A) 8 hr                                      B) 7 hr                                      C) 20 hr                                      D) 19 hr
- 18) A rectangular carpet has a perimeter of 192 inches. The length of the carpet is 76 inches more than the width. What are the dimensions of the carpet?
- A) 86 by 10 in.                              B) 86 by 96 in.                              C) 53 by 63 in.                              D) 91 by 96 in.
- 19) The perimeter of a triangle is 65 centimeters. Find the lengths of its sides, if the longest side is 7 centimeters longer than the shorter side, and the remaining side is 4 centimeters longer than the shorter side.
- A) 18 cm, 22 cm, 25 cm                                      B) 20 cm, 20 cm, 25 cm  
C) 18 cm, 23 cm, 25 cm                                      D) 20 cm, 21 cm, 24 cm

### 1.3 Quadratic Equations

#### 1 Solve Quadratic Equations by Factoring

**MULTIPLE CHOICE.** Choose the one alternative that best completes the statement or answers the question.

**Solve the equation by factoring.**

- 1)  $x^2 - 7x = 0$   
A) {0, 7}                                      B) {0, -7}                                      C) {7}                                      D) {-7}
- 2)  $6x^2 - 15x = 0$   
A)  $\left\{\frac{5}{2}, 0\right\}$                                       B)  $\left\{\frac{5}{2}, -\frac{5}{2}\right\}$                                       C) {0}                                      D)  $\left\{-\frac{5}{2}, 0\right\}$
- 3)  $28x^2 + 21x = 0$   
A)  $\left\{-\frac{3}{4}, 0\right\}$                                       B)  $\left\{\frac{3}{4}, -\frac{3}{4}\right\}$                                       C) {0}                                      D)  $\left\{\frac{3}{4}, 0\right\}$
- 4)  $x^2 - 49 = 0$   
A) {7, -7}                                      B) {7}                                      C) {-7}                                      D) {49}
- 5)  $x^2 + x - 72 = 0$   
A) {-9, 8}                                      B) {8, 9}                                      C) {-8, 9}                                      D) {-9, -8}
- 6)  $x^2 - 8x + 15 = 0$   
A) {3, 5}                                      B) {3, -5}                                      C) {-3, 5}                                      D) {-3, -5}
- 7)  $x^2 - 4x - 32 = 0$   
A) {-4, 8}                                      B) {-4, -8}                                      C) {4, -8}                                      D) {4, 8}
- 8)  $3x^2 + 5x - 12 = 0$   
A)  $\left\{\frac{4}{3}, -3\right\}$                                       B)  $\left\{\frac{4}{3}, 3\right\}$                                       C)  $\left\{-\frac{4}{3}, -3\right\}$                                       D)  $\left\{-\frac{4}{3}, 3\right\}$
- 9)  $2x^2 - 34 = 0$   
A)  $\{-\sqrt{17}, \sqrt{17}\}$                                       B) {18}                                      C) {-17, 17}                                      D) {17}

- 10)  $x(x - 6) + 5 = 0$   
 A)  $\{5, 1\}$                       B)  $\{5, -1\}$                       C)  $\{-5, 1\}$                       D)  $\{-5, -1\}$
- 11)  $x(x + 4) = 32$   
 A)  $\{-8, 4\}$                       B)  $\{8, -4\}$                       C)  $\{-8, -4\}$                       D)  $\{8, 4\}$
- 12)  $64x^2 - 112x + 49 = 0$   
 A)  $\left\{\frac{7}{8}\right\}$                       B)  $\left\{\frac{8}{7}\right\}$                       C)  $\left\{-\frac{7}{8}\right\}$                       D)  $\left\{-\frac{8}{7}\right\}$
- 13)  $12x^2 - 5x - 25 = 0$   
 A)  $\left\{-\frac{5}{4}, \frac{5}{3}\right\}$                       B)  $\left\{\frac{5}{4}, \frac{5}{3}\right\}$                       C)  $\left\{\frac{5}{4}, -\frac{5}{3}\right\}$                       D)  $\left\{-\frac{5}{4}, -\frac{5}{3}\right\}$
- 14)  $8x - 39 = \frac{5}{x}$   
 A)  $\left\{-\frac{1}{8}, 5\right\}$                       B)  $\left\{-\frac{1}{8}, 8\right\}$                       C)  $\left\{\frac{1}{39}, -\frac{1}{8}\right\}$                       D)  $\{-8, 5\}$
- 15)  $10x + \frac{18}{x} = -36$   
 A)  $\left\{-3, -\frac{3}{5}\right\}$                       B)  $\left\{3, \frac{3}{5}\right\}$                       C)  $\left\{-\frac{1}{3}, \frac{3}{5}\right\}$                       D)  $\left\{10, \frac{5}{3}\right\}$
- 16)  $\frac{x - 6}{x} = \frac{35}{x + 6}$   
 A)  $\{36, -1\}$                       B)  $\{36, 1\}$                       C)  $\{6, -1\}$                       D)  $\{6, 1\}$

## 2 Solve Quadratic Equations Using the Square Root Method

**MULTIPLE CHOICE.** Choose the one alternative that best completes the statement or answers the question.

**Solve the equation by the Square Root Method.**

- 1)  $x^2 = 121$   
 A)  $\{11, -11\}$                       B)  $\{11\}$                       C)  $\{12, -12\}$                       D)  $\{60.5\}$
- 2)  $x^2 = 6$   
 A)  $\{\sqrt{6}, -\sqrt{6}\}$                       B)  $\{6, -6\}$                       C)  $\{\sqrt{6}\}$                       D) no real solution
- 3)  $x^2 - 2 = 0$   
 A)  $\{\sqrt{2}, -\sqrt{2}\}$                       B)  $\{-2, 2\}$                       C)  $\{\sqrt{2}\}$                       D)  $\{2\}$
- 4)  $(x - 3)^2 = 49$   
 A)  $\{10, -4\}$                       B)  $\{52\}$                       C)  $\{7, -7\}$                       D)  $\{-4, -10\}$
- 5)  $(x + 5)^2 = 36$   
 A)  $\{-11, 1\}$                       B)  $\{1\}$                       C)  $\{-6, 6\}$                       D)  $\{-11\}$
- 6)  $(2x - 3)^2 = 9$   
 A)  $\{3, 0\}$                       B)  $\{0, -3\}$                       C)  $\{6, 0\}$                       D)  $\{0, -6\}$

- 7)  $(4x + 2)^2 = 36$   
 A)  $\{-2, 1\}$                       B)  $\{1, 2\}$                       C)  $\{-10, 10\}$                       D)  $\{0, 1\}$
- 8)  $(x + 6)^2 = 10$   
 A)  $\{-6 + \sqrt{10}, -6 - \sqrt{10}\}$                       B)  $\{6 + \sqrt{10}, 6 - \sqrt{10}\}$   
 C)  $\{\sqrt{10}, -\sqrt{10}\}$                       D)  $\{4\}$

### 3 Solve Quadratic Equations by Completing the Square

**MULTIPLE CHOICE.** Choose the one alternative that best completes the statement or answers the question.

**What number should be added to complete the square of the expression?**

- 1)  $x^2 + 12x$   
 A) 36                      B) 6                      C) 72                      D) 18
- 2)  $x^2 - 12x$   
 A) 36                      B) -6                      C) 72                      D) 18
- 3)  $x^2 + \frac{2}{5}x$   
 A)  $\frac{1}{25}$                       B)  $\frac{2}{25}$                       C)  $\frac{4}{25}$                       D)  $\frac{1}{5}$
- 4)  $x^2 - \frac{2}{3}x$   
 A)  $\frac{1}{9}$                       B)  $-\frac{2}{9}$                       C)  $\frac{4}{9}$                       D)  $-\frac{1}{3}$

**Solve the equation by completing the square.**

- 5)  $x^2 - x = 9$   
 A)  $\left\{\frac{1 - \sqrt{37}}{2}, \frac{1 + \sqrt{37}}{2}\right\}$                       B)  $\left\{\frac{-1 - \sqrt{37}}{2}, \frac{-1 + \sqrt{37}}{2}\right\}$   
 C)  $\left\{\frac{1 - \sqrt{37}}{4}, \frac{1 + \sqrt{37}}{4}\right\}$                       D)  $\left\{-\frac{5}{2}, \frac{7}{2}\right\}$
- 6)  $x^2 + 4x = 9$   
 A)  $\{-2 - \sqrt{13}, -2 + \sqrt{13}\}$                       B)  $\{2 + \sqrt{13}\}$   
 C)  $\{-1 - \sqrt{13}, -1 + \sqrt{13}\}$                       D)  $\{-2 - 2\sqrt{13}, -2 + 2\sqrt{13}\}$
- 7)  $x^2 + 8x - 3 = 0$   
 A)  $\{-4 - \sqrt{19}, -4 + \sqrt{19}\}$                       B)  $\{4 + \sqrt{19}\}$   
 C)  $\{-1 - \sqrt{19}, -1 + \sqrt{19}\}$                       D)  $\{4 - \sqrt{19}, 4 + \sqrt{19}\}$
- 8)  $x^2 - 12x + 11 = 0$   
 A)  $\{11, 1\}$                       B)  $\{-11, -1\}$                       C)  $\{\sqrt{5}, -1\}$                       D)  $\{10, 1\}$
- 9)  $x^2 + 14x + 39 = 0$   
 A)  $\{-7 - \sqrt{10}, -7 + \sqrt{10}\}$                       B)  $\{7 + \sqrt{10}\}$   
 C)  $\{7 - \sqrt{39}, 7 + \sqrt{39}\}$                       D)  $\{-14 + \sqrt{39}\}$

$$10) x^2 - 4x - 15 = 0$$

- A)  $\{2 - \sqrt{19}, 2 + \sqrt{19}\}$   
 C)  $\{-2 - \sqrt{19}, -2 + \sqrt{19}\}$

- B)  $\{2 - \sqrt{15}, 2 + \sqrt{15}\}$   
 D)  $\{4 - \sqrt{31}, 4 + \sqrt{31}\}$

$$11) x^2 + 5x - 5 = 0$$

- A)  $\left\{\frac{-5 - 3\sqrt{5}}{2}, \frac{-5 + 3\sqrt{5}}{2}\right\}$   
 C)  $\left\{\frac{-5 - 3\sqrt{5}}{2}\right\}$

- B)  $\left\{\frac{5 + 3\sqrt{5}}{2}\right\}$   
 D)  $\{-5 - 3\sqrt{5}, -5 + 3\sqrt{5}\}$

$$12) x^2 - 2x - \frac{5}{4} = 0$$

- A)  $\left\{\frac{5}{2}, -\frac{1}{2}\right\}$

- B)  $\left\{-\frac{5}{2}, -\frac{1}{2}\right\}$

- C)  $\left\{\frac{5}{2}, \frac{1}{2}\right\}$

- D)  $\left\{-\frac{5}{2}, \frac{1}{2}\right\}$

$$13) \frac{1}{2}x^2 + \frac{1}{8}x - \frac{1}{4} = 0$$

- A)  $\left\{\frac{\sqrt{33} - 1}{8}, -\frac{\sqrt{33} + 1}{8}\right\}$   
 C)  $\left\{\frac{1}{8}, -\frac{1}{8}\right\}$

- B)  $\left\{\frac{\sqrt{33}}{8}, -\frac{\sqrt{33}}{8}\right\}$   
 D)  $\left\{\frac{\sqrt{33} - 1}{8}, \frac{\sqrt{33} + 1}{8}\right\}$

$$14) 25x^2 + 70x + 48 = 0$$

- A)  $\left\{-\frac{6}{5}, -\frac{8}{5}\right\}$

- B)  $\left\{-\frac{6}{25}, -\frac{8}{25}\right\}$

- C)  $\left\{\frac{6}{5}, \frac{8}{5}\right\}$

- D)  $\left\{-\frac{8}{25}, \frac{56}{25}\right\}$

$$15) 5x^2 - 2x - 5 = 0$$

- A)  $\left\{\frac{1 - \sqrt{26}}{5}, \frac{1 + \sqrt{26}}{5}\right\}$   
 C)  $\left\{-5, \frac{27}{5}\right\}$

- B)  $\left\{\frac{5 - \sqrt{26}}{25}, \frac{5 + \sqrt{26}}{25}\right\}$   
 D)  $\left\{\frac{-1 - \sqrt{26}}{5}, \frac{-1 + \sqrt{26}}{5}\right\}$

#### 4 Solve Quadratic Equations Using the Quadratic Formula

**MULTIPLE CHOICE.** Choose the one alternative that best completes the statement or answers the question.

**Find the real solutions, if any, of the equation. Use the quadratic formula.**

$$1) x^2 + 8x - 5 = 0$$

- A)  $\{-4 - \sqrt{21}, -4 + \sqrt{21}\}$   
 C)  $\{-1 - \sqrt{21}, -1 + \sqrt{21}\}$

- B)  $\{4 + \sqrt{21}\}$   
 D)  $\{-4 - 1\sqrt{21}, -4 + 1\sqrt{21}\}$

$$2) x^2 - 8x - 3 = 0$$

- A)  $\{4 + \sqrt{19}, 4 - \sqrt{19}\}$   
 C)  $\{-4 + \sqrt{19}, -4 - \sqrt{19}\}$

- B)  $\{4 + \sqrt{3}, 4 - \sqrt{3}\}$   
 D)  $\{8 + \sqrt{19}, 8 - \sqrt{19}\}$

$$3) x^2 + x + 5 = 0$$

$$A) \left\{ \frac{-1 - \sqrt{19}}{2}, \frac{-1 + \sqrt{19}}{2} \right\}$$

$$C) \left\{ \frac{-1 - \sqrt{19}}{2}, \frac{1 + \sqrt{19}}{2} \right\}$$

$$B) \left\{ \frac{1 - \sqrt{19}}{2}, \frac{1 + \sqrt{19}}{2} \right\}$$

D) no real solution

$$4) 3x^2 + 13x - 10 = 0$$

$$A) \left\{ \frac{2}{3}, -5 \right\}$$

$$B) \left\{ \frac{2}{3}, 5 \right\}$$

$$C) \left\{ -\frac{2}{3}, -5 \right\}$$

$$D) \left\{ -\frac{2}{3}, 5 \right\}$$

$$5) 4x^2 - x + 2 = 0$$

$$A) \left\{ \frac{-1 - \sqrt{33}}{8}, \frac{-1 + \sqrt{33}}{8} \right\}$$

$$C) \left\{ \frac{-1 - \sqrt{33}}{8}, \frac{1 + \sqrt{33}}{8} \right\}$$

$$B) \left\{ \frac{-1 + \sqrt{33}}{8}, \frac{1 + \sqrt{33}}{8} \right\}$$

D) no real solution

$$6) x^2 + 5x + 5 = 0$$

$$A) \left\{ \frac{-5 - \sqrt{5}}{2}, \frac{-5 + \sqrt{5}}{2} \right\}$$

$$C) \left\{ \frac{-5 - \sqrt{5}}{10}, \frac{-5 + \sqrt{5}}{10} \right\}$$

$$B) \left\{ \frac{5 - \sqrt{5}}{2}, \frac{5 + \sqrt{5}}{2} \right\}$$

$$D) \left\{ \frac{-5 - 3\sqrt{5}}{2}, \frac{-5 + 3\sqrt{5}}{2} \right\}$$

$$7) 5x^2 + x - 2 = 0$$

$$A) \left\{ \frac{-1 - \sqrt{41}}{10}, \frac{-1 + \sqrt{41}}{10} \right\}$$

$$C) \left\{ \frac{1 - \sqrt{41}}{10}, \frac{1 + \sqrt{41}}{10} \right\}$$

$$B) \left\{ \frac{-1 - \sqrt{41}}{2}, \frac{-1 + \sqrt{41}}{2} \right\}$$

D) no real solution

$$8) 2x^2 + 12x + 5 = 0$$

$$A) \left\{ \frac{-6 - \sqrt{26}}{2}, \frac{-6 + \sqrt{26}}{2} \right\}$$

$$C) \left\{ \frac{-12 - \sqrt{26}}{2}, \frac{-12 + \sqrt{26}}{2} \right\}$$

$$B) \left\{ \frac{-6 - \sqrt{26}}{4}, \frac{-6 + \sqrt{26}}{4} \right\}$$

$$D) \left\{ \frac{-6 - \sqrt{46}}{2}, \frac{-6 + \sqrt{46}}{2} \right\}$$

$$9) 25x^2 - 40x + 16 = 0$$

$$A) \left\{ \frac{4}{5} \right\}$$

$$B) \left\{ -\frac{4}{5} \right\}$$

$$C) \left\{ \frac{4}{5}, -20 \right\}$$

D) no real solution

$$10) 16x^2 + 21 = 40x$$

$$A) \left\{ \frac{7}{4}, \frac{3}{4} \right\}$$

$$B) \left\{ \frac{7}{16}, \frac{3}{16} \right\}$$

$$C) \left\{ -\frac{7}{4}, -\frac{3}{4} \right\}$$

$$D) \left\{ \frac{3}{16}, \frac{9}{8} \right\}$$

$$11) 2x^2 + 8x = -3$$

$$A) \left\{ \frac{-4 - \sqrt{10}}{2}, \frac{-4 + \sqrt{10}}{2} \right\}$$

$$C) \left\{ \frac{-8 - \sqrt{10}}{2}, \frac{-8 + \sqrt{10}}{2} \right\}$$

$$B) \left\{ \frac{-4 - \sqrt{10}}{4}, \frac{-4 + \sqrt{10}}{4} \right\}$$

$$D) \left\{ \frac{-4 - \sqrt{22}}{2}, \frac{-4 + \sqrt{22}}{2} \right\}$$

12)  $7x^2 = -8x - 2$

A)  $\left\{ \frac{-4 - \sqrt{2}}{7}, \frac{-4 + \sqrt{2}}{7} \right\}$   
 C)  $\left\{ \frac{-8 - \sqrt{2}}{7}, \frac{-8 + \sqrt{2}}{7} \right\}$

B)  $\left\{ \frac{-4 - \sqrt{2}}{14}, \frac{-4 + \sqrt{2}}{14} \right\}$   
 D)  $\left\{ \frac{-4 - \sqrt{30}}{7}, \frac{-4 + \sqrt{30}}{7} \right\}$

13)  $4x = 1 + \frac{-7}{x}$

A)  $\left\{ \frac{1 - \sqrt{113}}{8}, \frac{1 + \sqrt{113}}{8} \right\}$   
 C)  $\left\{ \frac{1 - \sqrt{113}}{8} \right\}$

B)  $\left\{ -\frac{1 + \sqrt{113}}{8}, \frac{1 - \sqrt{113}}{8} \right\}$   
 D) no real solution

14)  $3 + \frac{10}{x} + \frac{1}{x^2} = 0$

A)  $\left\{ \frac{-5 - \sqrt{22}}{3}, \frac{-5 + \sqrt{22}}{3} \right\}$   
 C)  $\left\{ \frac{5 - \sqrt{22}}{3}, \frac{5 + \sqrt{22}}{3} \right\}$

B)  $\left\{ \frac{-5 - \sqrt{22}}{6}, \frac{-5 + \sqrt{22}}{6} \right\}$   
 D) no real solution

Use the discriminant to determine whether the quadratic equation has two unequal real solutions, a repeated real solution, or no real solution without solving the equation.

15)  $x^2 - 6x + 8 = 0$

- A) repeated real solution                      B) two unequal real solutions                      C) no real solution

16)  $x^2 + 4x + 4 = 0$

- A) repeated real solution                      B) two unequal real solutions                      C) no real solution

17)  $x^2 - 3x + 5 = 0$

- A) repeated real solution                      B) two unequal real solutions                      C) no real solution

18)  $5x^2 - 4x + 3 = 0$

- A) repeated real solution                      B) two unequal real solutions                      C) no real solution

19)  $8x^2 - 2x - 2 = 0$

- A) repeated real solution                      B) two unequal real solutions                      C) no real solution

## 5 Solve Problems That Can Be Modeled by Quadratic Equations

**MULTIPLE CHOICE.** Choose the one alternative that best completes the statement or answers the question.

**Solve the problem.**

1) The length of a vegetable garden is 8 feet longer than its width. If the area of the garden is 65 square feet, find its dimensions.

- A) 5 ft by 13 ft                      B) 4 ft by 14 ft                      C) 6 ft by 14 ft                      D) 4 ft by 12 ft

2) Find the dimensions of a rectangle whose perimeter is 46 meters and whose area is 120 square meters.

- A) 8 m by 15 m                      B) 7 m by 16 m                      C) 9 m by 14 m                      D) 7 m by 14 m

- 3) The area of a circle is found by the equation  $A = \pi r^2$ . If the area  $A$  of a certain circle is  $4\pi$  square centimeters, find its radius  $r$ .
- A) 2 cm                      B)  $2\pi$  cm                      C)  $2\sqrt{\pi}$  cm                      D) {2 cm,  $-2$  cm}
- 4) A 21-inch-square TV is on sale at the local electronics store. If 21 inches is the measure of the diagonal of the screen, use the Pythagorean theorem to find the length of the side of the screen.
- A)  $\frac{21\sqrt{2}}{2}$  in.                      B)  $\sqrt{21}$  in.                      C)  $\frac{\sqrt{21}}{2}$  in.                      D)  $\frac{441}{2}$  in.
- 5) An open box is to be constructed from a square sheet of plastic by removing a square of side 2 inches from each corner and turning up the sides. If the box must have a volume of 242 cubic inches, what is the length of one side of the open box?
- A) 11 in.                      B) 13 in.                      C) 15 in.                      D) 10 in.
- 6) An open box is to be made from a square sheet of cardboard by cutting out 2-inch squares from each corner and turning up the sides. If the box is to have a volume of 98 cubic inches, what are the original dimensions of the sheet of cardboard?
- A) 11 in. by 11 in.                      B)  $7\sqrt{2}$  in. by  $7\sqrt{2}$  in.                      C)  $\sqrt{7}$  in. by  $\sqrt{14}$  in.                      D) 7 in. by 7 in.
- 7) A ball is thrown vertically upward from the top of a building 112 feet tall with an initial velocity of 96 feet per second. The distance  $s$  (in feet) of the ball from the ground after  $t$  seconds is  $s = 112 + 96t - 16t^2$ . After how many seconds does the ball strike the ground?
- A) 7 sec                      B) 113 sec                      C) 6 sec                      D) 9 sec
- 8) As part of a physics experiment, Ming drops a baseball from the top of a 300-foot building. To the nearest tenth of a second, for how many seconds will the baseball fall? (Hint: Use the formula  $h = 16t^2$ , which gives the distance  $h$ , in feet, that a free-falling object travels in  $t$  seconds.)
- A) 4.3 sec                      B) 75 sec                      C) 18.8 sec                      D) 1.1 sec
- 9) The net income  $y$  (in millions of dollars) of Pet Products Unlimited from 1997 to 1999 is given by the equation  $y = 9x^2 + 15x + 52$ , where  $x$  represents the number of years after 1997. Assume this trend continues and predict the year in which Pet Products Unlimited's net income will be \$916 million.
- A) 2006                      B) 2008                      C) 2005                      D) 2007
- 10) The formula  $A = P(1 + r)^2$  is used to find the amount of money,  $A$ , in an account after  $P$  dollars have been invested in the account paying an annual interest rate,  $r$ , for 2 years. Find the interest rate  $r$  if \$500 grows to \$980 in 2 years.
- A) 40%                      B) 96%                      C) 4%                      D) 240%

- 11) A circular pool measures 16 feet across. One cubic yard of concrete is to be used to create a circular border of uniform width around the pool. If the border is to have a depth of 3 inches, how wide will the border be? Use 3.14 to approximate  $\pi$ . Express your solution rounded to two decimal places. (1 cubic yard = 27 cubic feet)

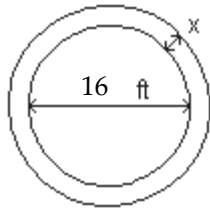

- A) 1.92 ft                      B) 12.47 ft                      C) 5.53 ft                      D) 10.63 ft
- 12) If a polygon of  $n$  sides has  $\frac{1}{2}n(n - 3)$  diagonals, how many sides will a polygon with 90 diagonals have?  
 A) 15 sides                      B) 16 sides                      C) 14 sides                      D) 17 sides
- 13) Find a positive value of  $k$  such that the equation  $x^2 + kx + 9 = 0$  has a repeated real solution.  
 A) 6                                  B) 5                                  C) 4                                  D) 7

## 1.4 Complex Numbers; Quadratic Equations in the Complex Number System

### 1 Add, Subtract, Multiply, and Divide Complex Numbers

**MULTIPLE CHOICE.** Choose the one alternative that best completes the statement or answers the question.

Write the expression in the standard form  $a + bi$ .

- 1)  $(2 - 7i) + (6 + 5i)$   
 A)  $8 - 2i$                       B)  $8 + 2i$                       C)  $-4 + 12i$                       D)  $-8 + 2i$
- 2)  $(7 + 6i) - (-3 + i)$   
 A)  $10 + 5i$                       B)  $10 - 5i$                       C)  $4 + 7i$                       D)  $-10 - 5i$
- 3)  $9(3 - 4i)$   
 A)  $27 - 36i$                       B)  $27 + 36i$                       C)  $27i - 4i$                       D)  $3 - 36i$
- 4)  $4i(7 - 2i)$   
 A)  $8 + 28i$                       B)  $28i - 8$                       C)  $28i - 8i^2$                       D)  $28i + 8i^2$
- 5)  $-2i(-3 + 2i)$   
 A)  $4 + 6i$                       B)  $-4 + 6i$                       C)  $6i - 4i^2$                       D)  $6i + 4i^2$
- 6)  $(-2 + 5i)(3 + i)$   
 A)  $-11 + 13i$                       B)  $-1 + 13i$                       C)  $-11 - 17i$                       D)  $-1 - 17i$
- 7)  $(5 + 2i)(9 + 5i)$   
 A)  $35 + 43i$                       B)  $35 - 43i$                       C)  $55 - 7i$                       D)  $10i^2 + 43i + 45$
- 8)  $(6 + 3i)(6 - 7i)$   
 A)  $57 - 24i$                       B)  $57 + 24i$                       C)  $15 + 60i$                       D)  $-21i^2 - 24i + 36$



9)  $(6 + 5i)(6 - 5i)$

A) 61

B)  $36 - 25i^2$

C) 11

D)  $36 - 25i$

10)  $(-9 + i)(-9 - i)$

A) 82

B) -9

C) 81

D) -80

11)  $(1 + 2i)(1 - 2i)$

A) 5

B)  $1 - 4i^2$

C) -3

D)  $1 - 4i$

12)  $\frac{3}{8 + i}$

A)  $\frac{24}{65} - \frac{3}{65}i$

B)  $\frac{24}{65} + \frac{3}{65}i$

C)  $\frac{8}{21} + \frac{1}{21}i$

D)  $\frac{8}{21} - \frac{1}{21}i$

13)  $\frac{9}{3 - i}$

A)  $\frac{27}{10} + \frac{9}{10}i$

B)  $\frac{27}{10} - \frac{9}{10}i$

C)  $\frac{27}{8} + \frac{9}{8}i$

D)  $\frac{27}{8} - \frac{9}{8}i$

14)  $\frac{8}{3 + 7i}$

A)  $\frac{12}{29} - \frac{28}{29}i$

B)  $\frac{12}{29} + \frac{28}{29}i$

C)  $-\frac{3}{5} - \frac{7}{5}i$

D)  $-\frac{3}{5} + \frac{7}{5}i$

15)  $\frac{5i}{2 - i}$

A)  $-1 + 2i$

B)  $1 + 2i$

C)  $-1 + 5i$

D)  $-1 - 2i$

16)  $\frac{6 + 5i}{5 - 6i}$

A)  $i$

B)  $-i$

C) 1

D) -1

17)  $\frac{24 - 3i}{3 - 6i}$

A)  $2 + 3i$

B)  $2 - 3i$

C)  $3 + 2i$

D)  $3 - 2i$

18)  $\frac{5 + 5i}{8 - 5i}$

A)  $\frac{15}{89} + \frac{65}{89}i$

B)  $\frac{5}{13} - \frac{5}{3}i$

C)  $\frac{65}{89} - \frac{15}{89}i$

D)  $\frac{5}{3} - \frac{5}{3}i$

19)  $(6 + 3i)^2$

A)  $27 + 36i$

B)  $45 + 36i$

C) 27

D)  $36 + 36i + 9i^2$

20)  $\left(\frac{\sqrt{2}}{2} + \frac{\sqrt{2}}{2}i\right)^2$

A)  $i$

B)  $-i$

C)  $\frac{i}{2}$

D)  $-\frac{i}{2}$

- 21)  $i^4$   
 A) 1                                      B) -1                                      C) i                                      D) -i
- 22)  $i^3$   
 A) -i                                      B) i                                      C) 1                                      D) -1
- 23)  $i^{13}$   
 A) i                                      B) -i                                      C) 1                                      D) -1
- 24)  $i^6$   
 A) -1                                      B) 1                                      C) i                                      D) -i
- 25)  $2i^{15} - i^7$   
 A) -i                                      B) i                                      C) -1                                      D) 1
- 26)  $5i^5(1 + i^3)$   
 A)  $5 + 5i$                                       B)  $5 - 5i$                                       C)  $-5 - 5i$                                       D)  $-5 + 5i$
- 27)  $(1 + i)^7$   
 A)  $8 - 8i$                                       B)  $-8 - 8i$                                       C)  $8 + 8i$                                       D)  $8 + i$
- 28)  $i^{18} + i^{16} + i^{14} + 1$   
 A) 0                                      B) 1                                      C) i                                      D) -1

**Perform the indicated operations and express your answer in the form  $a + bi$ .**

- 29)  $\sqrt{-4}$   
 A)  $2i$                                       B)  $-i\sqrt{2}$                                       C)  $-2i$                                       D)  $\pm 2$
- 30)  $\sqrt{-36}$   
 A)  $6i$                                       B)  $i\sqrt{6}$                                       C)  $-6i$                                       D)  $\pm 6$
- 31)  $\sqrt{(8 + 6i)(6i - 8)}$   
 A)  $10i$                                       B)  $-10i$                                       C)  $-10$                                       D)  $10$

**Write the expression in the standard form  $a + bi$ .**

- 32) Given  $z = 4 - 3i$ , evaluate  $z + \bar{z}$ .  
 A) 8                                      B)  $8 - 6i$                                       C)  $-6i$                                       D)  $8 + 6i$
- 33) Given  $w = 9 + 4i$ , evaluate  $w - \bar{w}$ .  
 A)  $8i$                                       B)  $-18 + 8i$                                       C) 18                                      D) 0
- 34) Given  $z = 1 - 8i$ , evaluate  $z\bar{z}$ .  
 A) 65                                      B)  $1 - 64i^2$                                       C) -63                                      D)  $1 - 64i$
- 35) Given  $z = 7 + 5i$  and  $w = -3 + i$ , evaluate  $\overline{z - w}$ .  
 A)  $10 - 4i$                                       B)  $10 + 4i$                                       C)  $4 + 6i$                                       D)  $-10 - 4i$
- 36) Given  $z = 7 - 3i$  and  $w = 9 + 6i$ , evaluate  $\overline{\overline{z + w}}$ .  
 A)  $16 + 3i$                                       B)  $16 - 3i$                                       C)  $-2 + 9i$                                       D)  $-16 - 3i$

**Solve the problem.**

37) The impedance  $Z$ , in ohms, of a circuit element is defined as the ratio of the phasor voltage  $V$ , in volts, across the element to the phasor current  $I$ , in amperes, through the element. That is,  $Z = \frac{V}{I}$ . If the voltage across a circuit element is  $7 + i$  volts and the current through the element is  $2 - 3i$  amperes, what is the impedance?

- A)  $\frac{11}{13} + \frac{23}{13}i$  ohms      B)  $\frac{34}{13}$  ohms      C)  $\frac{17}{13} + \frac{23}{13}i$  ohms      D)  $\frac{40}{13}$  ohms

38) In an ac circuit with two parallel pathways, the total impedance  $Z$ , in ohms, satisfies the formula  $\frac{1}{Z} = \frac{1}{Z_1} + \frac{1}{Z_2}$ , where  $Z_1$  is the impedance of the first pathway and  $Z_2$  is the impedance of the second pathway. Determine the total impedance if the impedances of the two pathways are  $Z_1 = 4 + i$  ohms and  $Z_2 = 7 - i$  ohms.

- A)  $\frac{29}{11} + \frac{3}{11}i$  ohms      B)  $\frac{27}{11} + \frac{3}{11}i$  ohms      C)  $\frac{26}{11}$  ohms      D)  $\frac{24}{11}$  ohms

**2 Solve Quadratic Equations in the Complex Number System**

**MULTIPLE CHOICE.** Choose the one alternative that best completes the statement or answers the question.

**Solve the equation in the complex number system.**

1)  $x^2 + 49 = 0$

- A)  $\{-7i, 7i\}$       B)  $\{7i\}$       C)  $\{7\}$       D)  $\{-7, 7\}$

2)  $x^2 - 8x + 25 = 0$

- A)  $\{4 + 3i, 4 - 3i\}$       B)  $\{4 - 9i, 4 + 9i\}$       C)  $\{4 + 3i\}$       D)  $\{7, 1\}$

3)  $4x^2 - 3x + 1 = 0$

- A)  $\left\{\frac{3}{8} - \frac{\sqrt{7}}{8}i, \frac{3}{8} + \frac{\sqrt{7}}{8}i\right\}$       B)  $\left\{-\frac{3}{8} - \frac{\sqrt{7}}{8}i, \frac{3}{8} + \frac{\sqrt{7}}{8}i\right\}$   
 C)  $\left\{\frac{3}{8} - \frac{\sqrt{7}}{8}i, -\frac{3}{8} + \frac{\sqrt{7}}{8}i\right\}$       D)  $\left\{-\frac{3}{8} - \frac{\sqrt{7}}{8}i, -\frac{3}{8} + \frac{\sqrt{7}}{8}i\right\}$

4)  $x^2 + x + 6 = 0$

- A)  $\left\{-\frac{1}{2} - \frac{\sqrt{23}}{2}i, -\frac{1}{2} + \frac{\sqrt{23}}{2}i\right\}$       B)  $\left\{\frac{1 - \sqrt{23}}{2}, \frac{1 + \sqrt{23}}{2}\right\}$   
 C)  $\left\{\frac{1}{2} - \frac{\sqrt{23}}{2}i, \frac{1}{2} + \frac{\sqrt{23}}{2}i\right\}$       D)  $\left\{\frac{-1 - \sqrt{23}}{2}, \frac{-1 + \sqrt{23}}{2}\right\}$

5)  $x^3 - 125 = 0$

- A)  $\left\{5, -\frac{5}{2} - \frac{5\sqrt{3}}{2}i, -\frac{5}{2} + \frac{5\sqrt{3}}{2}i\right\}$       B)  $\left\{5, -\frac{5}{2} - \frac{5\sqrt{3}}{2}, -\frac{5}{2} + \frac{5\sqrt{3}}{2}\right\}$   
 C)  $\{5, -5i, 5i\}$       D)  $\{5\}$

6)  $x^4 - 625 = 0$

- A)  $\{-5, 5, -5i, 5i\}$       B)  $\{-5, 5\}$       C)  $\{5\}$       D)  $\{-5, 5, 5i\}$

7)  $x^4 - 2x^2 - 3 = 0$

A)  $\{-\sqrt{3}, \sqrt{3}, i, -i\}$

B)  $\{\sqrt{3}i, i\}$

C)  $\{-\sqrt{3}i, -i\}$

D)  $\{\sqrt{3}, 3\}$

Without solving, determine the character of the solutions of the equation in the complex number system.

8)  $x^2 + 3x + 2 = 0$

A) a repeated real solution

B) two unequal real solutions

C) two complex solutions that are conjugates of each other

9)  $x^2 - 8x + 16 = 0$

A) a repeated real solution

B) two unequal real solutions

C) two complex solutions that are conjugates of each other

10)  $x^2 - 2x + 7 = 0$

A) a repeated real solution

B) two unequal real solutions

C) two complex solutions that are conjugates of each other

11)  $4x^2 - 5x + 3 = 0$

A) a repeated real solution

B) two unequal real solutions

C) two complex solutions that are conjugates of each other

12)  $3x^2 - 6x + 2 = 0$

A) a repeated real solution

B) two unequal real solutions

C) two complex solutions that are conjugates of each other

13)  $4x^2 - 4x + 1 = 0$

A) a repeated real solution

B) two unequal real solutions

C) two complex solutions that are conjugates of each other

Solve the problem.

14)  $1 - i$  is a solution of a quadratic equation with real coefficients. Find the other solution.

A)  $1 + i$

B)  $1 - i$

C)  $-1 + i$

D)  $-1 - i$

15)  $3 + 9i$  is a solution of a quadratic equation with real coefficients. Find the other solution.

A)  $3 - 9i$

B)  $-3 - 9i$

C)  $-3 + 9i$

D)  $3 + 9i$

## 1.5 Radical Equations; Equations Quadratic in Form; Absolute Value Equations; Factorable Equations

### 1 Solve Radical Equations

**MULTIPLE CHOICE.** Choose the one alternative that best completes the statement or answers the question.

Find the real solutions of the equation.

1)  $\sqrt{x + 2} = 7$

A)  $\{47\}$

B)  $\{49\}$

C)  $\{51\}$

D)  $\{81\}$

- 2)  $\sqrt{10x - 9} = 9$   
 A) {9}                      B) {81}                      C)  $\left\{\frac{36}{5}\right\}$                       D)  $\left\{\frac{81}{10}\right\}$
- 3)  $\sqrt{5x + 6} = 6$   
 A) {6}                      B) {36}                      C)  $\left\{\frac{42}{5}\right\}$                       D)  $\left\{\frac{36}{5}\right\}$
- 4)  $\sqrt[3]{2x + 4} = -2$   
 A) {-6}                      B) {0}                      C) {-4}                      D) {-5}
- 5)  $\sqrt[5]{1 - x} = -2$   
 A) {33}                      B) {-32}                      C) {-33}                      D) {32}
- 6)  $\sqrt[3]{1 + x} = -1$   
 A) {-2}                      B) {2}                      C) {-1}                      D) {1}
- 7)  $x = 9\sqrt{x}$   
 A) {0, 81}                      B) {0, 9}                      C) {-81, 81}                      D) {-9, 9}
- 8)  $\sqrt{6x + 40} = x$   
 A) {10}                      B) {-4, 10}                      C) {-8}                      D) no real solution
- 9)  $\sqrt{28x - 28} = x + 6$   
 A) {8}                      B) {-7}                      C) {-8}                      D) {10}
- 10)  $\sqrt{x + 7} + \sqrt{x} = 3$   
 A)  $\left\{\frac{1}{9}\right\}$                       B) {4}                      C) {1}                      D) no real solution
- 11)  $\sqrt{x^2 - 5x + 81} = x + 4$   
 A) {5}                      B) {-5}                      C)  $\left\{-\frac{5}{2}\right\}$                       D) {9}
- 12)  $\sqrt{x^2 - 3x + 60} = x + 4$   
 A) {4}                      B) {-4}                      C) {8}                      D) {0}
- 13)  $\sqrt{x^2 + 2} - \sqrt{2x + 5} = 0$   
 A) {3, -1}                      B) {-3, 1}                      C) {3}                      D) no real solution
- 14)  $\sqrt{2x + 3} - \sqrt{x + 1} = 1$   
 A) {3, -1}                      B) {3}                      C) {-3, -1}                      D) no real solution
- 15)  $\sqrt{2x + 5} - \sqrt{x - 2} = 3$   
 A) {2, 38}                      B) {3, 8}                      C) {2}                      D) {-2}
- 16)  $\sqrt{3x + 10} - \sqrt{x + 2} = 2$   
 A) {-2, 2}                      B) {2}                      C) {-3}                      D) {-2}

- 17)  $\sqrt{2 - 3\sqrt{x}} = 6$   
 A)  $\left\{\sqrt{\frac{34}{3}}\right\}$       B)  $\left\{-\sqrt{\frac{34}{3}}\right\}$       C)  $\left\{\sqrt{\frac{2}{3}}\right\}$       D) no real solution
- 18)  $\sqrt{1 + 14\sqrt{x}} = 1 + \sqrt{x}$   
 A)  $\{0, 144\}$       B)  $\left\{0, \frac{4}{13}\right\}$       C)  $\{0, 196\}$       D)  $\{0, 256\}$
- 19)  $(9x - 8)^{1/2} = 8$   
 A)  $\{8\}$       B)  $\{64\}$       C)  $\left\{\frac{56}{9}\right\}$       D)  $\left\{\frac{64}{9}\right\}$
- 20)  $(5x + 2)^{1/2} = 4$   
 A)  $\left\{\frac{14}{5}\right\}$       B)  $\left\{\frac{16}{5}\right\}$       C)  $\left\{-\frac{2}{5}\right\}$       D)  $\{10\}$
- 21)  $(3x + 5)^{1/3} = 5$   
 A)  $\{40\}$       B)  $\left\{\frac{20}{3}\right\}$       C)  $\left\{\frac{125}{3}\right\}$       D)  $\left\{\frac{122}{5}\right\}$
- 22)  $(x + 3)^{1/3} = -2$   
 A)  $\{-11\}$       B)  $\{1\}$       C)  $\{-9\}$       D) no real solution
- 23)  $(x^2 + 5)^{1/2} = 10$   
 A)  $\{\sqrt{95}, -\sqrt{95}\}$       B)  $\{95, -95\}$       C)  $\{\sqrt{5}\}$       D)  $\{5\}$
- 24)  $x^{3/4} - 2x^{1/4} = 0$   
 A)  $\{0, 4\}$       B)  $\{0, 16\}$       C)  $\{\sqrt{2}\}$       D)  $\{2\}$
- 25)  $x^{5/4} - 4x^{1/4} = 0$   
 A)  $\{0, 4\}$       B)  $\{-4, 0, 4\}$       C)  $\{0, 2\}$       D)  $\{0\}$

**Solve the problem.**

- 26) Find all points having an x-coordinate of 11 whose distance from the point  $(-1, -2)$  is 13.  
 A)  $(11, 3); (11, -7)$       B)  $(11, 3); (11, -3)$       C)  $(11, 7); (11, -7)$       D)  $(11, 7); (11, -3)$
- 27) Find all points on the y-axis that are 13 units from the point  $(-5, 1)$ .  
 A)  $(0, 13); (0, -11)$       B)  $(0, 6); (0, -4)$       C)  $(0, -13); (0, 11)$       D)  $(13, 0); (-11, 0)$
- 28) For a cone, the formula  $r = \sqrt{\frac{3V}{\pi h}}$  describes the relationship between the radius  $r$  of the base, the volume  $V$ , and the height  $h$ . Find the volume if the radius is 7 inches and the cone is 12 inches high. (Use 3.14 as an approximation for  $\pi$ , and round to the nearest tenth.)  
 A) 615.4 cu in.      B) 87.9 cu in.      C) 5539.0 cu in.      D) 51.3 cu in.
- 29) The formula  $v = \sqrt{2.5r}$  can be used to estimate the maximum safe velocity  $v$ , in miles per hour, at which a car can travel along a curved road with a radius of curvature  $r$ , in feet. To the nearest whole number, find the radius of curvature if the maximum safe velocity is 35 miles per hour.  
 A) 490 ft      B) 3063 ft      C) 196 ft      D) 1225 ft

- 30) The function  $f(x) = 6.75\sqrt{x} + 12$  models the amount,  $f(x)$ , in billions of dollars of new student loans  $x$  years after 1993. According to the model, in what year is the amount loaned expected to reach \$25.5 billion?  
 A) 1997                                      B) 2000                                      C) 2002                                      D) 2001
- 31) When an object is dropped to the ground from a height of  $h$  meters, the time it takes for the object to reach the ground is given by the equation  $t = \sqrt{\frac{h}{4.9}}$ , where  $t$  is measured in seconds. Solve the equation for  $h$ .  
 Use the result to determine the height from which an object was dropped if it hits the ground after falling for 5 seconds.  
 A)  $h = 4.9t^2$ ; 122.5 m                                      B)  $h = 24.01t$ ; 120.1 m  
 C)  $h = 24.01t^2$ ; 600.3 m                                      D)  $h = 4.9t$ ; 24.5 m
- 32) The maximum number of volts,  $E$ , that can be placed across a resistor is given by the formula  $E = \sqrt{PR}$ , where  $P$  is the number of watts of power that the resistor can absorb and  $R$  is the resistance of the resistor in ohms. Solve this equation for  $R$ . Use the result to determine the resistance of a resistor if  $P$  is  $\frac{1}{2}$  watts and  $E$  is 50 volts.  
 A)  $R = \frac{E^2}{P}$ ; 5000 ohms                                      B)  $R = \frac{E^2}{P^2}$ ; 10,000 ohms  
 C)  $R = E^2P$ ; 5000 ohms                                      D)  $R = E^2P^2$ ; 10,000 ohms
- 33) The number of centimeters,  $d$ , that a spring is compressed from its natural, uncompressed position is given by the formula  $d = \sqrt{\frac{2W}{k}}$ , where  $W$  is the number of joules of work done to move the spring and  $k$  is the spring constant. Solve this equation for  $W$ . Use the result to determine the work needed to move a spring 8 centimeters if it has a spring constant of 0.6.  
 A)  $W = \frac{d^2k}{2}$ ; 19.2 joules                                      B)  $W = \frac{d^2k^2}{4}$ ; 5.8 joules  
 C)  $W = \frac{2d^2}{k}$ ; 213.3 joules                                      D)  $W = 2d^2k$ ; 76.8 joules

## 2 Solve Equations Quadratic in Form

**MULTIPLE CHOICE.** Choose the one alternative that best completes the statement or answers the question.

**Find the real solutions of the equation.**

1)  $x^4 - 50x^2 + 49 = 0$

A)  $\{-1, 1, -7, 7\}$

B)  $\{-7, 7\}$

C)  $\{-49, 49\}$

D)  $\{-50, 50\}$

2)  $5x^4 + 7x^2 - 6 = 0$

A)  $\left\{-\sqrt{\frac{3}{5}}, \sqrt{\frac{3}{5}}\right\}$

B)  $\left\{-\frac{3}{5}, \frac{3}{5}\right\}$

C)  $\left\{-\sqrt{\frac{2}{5}}, \sqrt{\frac{2}{5}}\right\}$

D)  $\{-\sqrt{2}, \sqrt{2}\}$

3)  $x^6 - 63x^3 - 64 = 0$

A)  $\{4, -1\}$

B)  $\{64\}$

C)  $\{4\}$

D)  $\{-4, 1\}$

$$4) 3(x + 1)^2 + 19(x + 1) + 20 = 0$$

$$A) \left\{ -\frac{7}{3}, -6 \right\}$$

$$B) \{1, 4\}$$

$$C) \left\{ -\frac{4}{3}, -6 \right\}$$

$$D) \left\{ -\frac{7}{3}, -5 \right\}$$

$$5) (3x - 5)^2 - 3(3x - 5) - 18 = 0$$

$$A) \left\{ \frac{11}{3}, \frac{2}{3} \right\}$$

$$B) \left\{ -\frac{11}{3}, -\frac{2}{3} \right\}$$

$$C) \left\{ \frac{1}{3}, -\frac{8}{3} \right\}$$

$$D) \left\{ -\frac{1}{5}, \frac{8}{3} \right\}$$

$$6) (x - 4)^2 + 3(x - 4) - 18 = 0$$

$$A) \{-2, 7\}$$

$$B) \{-7, 2\}$$

$$C) \{-6, 1\}$$

$$D) \{-1, 6\}$$

$$7) x + \sqrt{x} = 42$$

$$A) \{36\}$$

$$B) \{6\}$$

$$C) \{7\}$$

$$D) \{49\}$$

$$8) x + 3x^{1/2} + 2 = 0$$

$$A) \{1, 4\}$$

$$B) \{-1, -2\}$$

$$C) \left\{ \frac{1}{4} \right\}$$

$$D) \text{no real solution}$$

$$9) x^{1/2} - 9x^{1/4} + 20 = 0$$

$$A) \{625, 256\}$$

$$B) \{25, 16\}$$

$$C) \{5, 4\}$$

$$D) \{-5, -4\}$$

$$10) x^2 + 5x - \sqrt{x^2 + 5x} = 42$$

$$A) \left\{ \frac{-5 + \sqrt{221}}{2}, \frac{-5 - \sqrt{221}}{2} \right\}$$

$$B) \{25, -25\}$$

$$C) \{6\}$$

$$D) \{5\}$$

$$11) \frac{1}{(x - 2)^2} - \frac{2}{x - 2} = 3$$

$$A) \left\{ 1, \frac{7}{3} \right\}$$

$$B) \left\{ -1, \frac{1}{3} \right\}$$

$$C) \left\{ 1, \frac{1}{3} \right\}$$

$$D) \left\{ -1, \frac{7}{3} \right\}$$

$$12) 2 + \frac{5}{5x - 1} = \frac{-2}{(5x - 1)^2}$$

$$A) \left\{ -\frac{1}{5}, \frac{1}{10} \right\}$$

$$B) \left\{ -2, -\frac{1}{2} \right\}$$

$$C) \left\{ -\frac{1}{5}, 0 \right\}$$

$$D) \left\{ -\frac{1}{5}, -\frac{1}{10} \right\}$$

$$13) 2x^{-2} + 2x^{-1} - 4 = 0$$

$$A) \left\{ -\frac{1}{2}, 1 \right\}$$

$$B) \left\{ \frac{1}{2}, 1 \right\}$$

$$C) \{-2, -1\}$$

$$D) \{-2, 1\}$$

$$14) x^{2/3} + 2x^{1/3} - 3 = 0$$

$$A) \{-27, 1\}$$

$$B) \{-3, 1\}$$

$$C) \{-1, 3\}$$

$$D) \{-1, 27\}$$

$$15) x^{2/3} - 4x^{1/3} + 3 = 0$$

$$A) \{1, 27\}$$

$$B) \{1, 3\}$$

$$C) \{-3, -1\}$$

$$D) \{-27, -1\}$$



Find the real solutions of the equation. Use a calculator to express the solutions rounded to two decimal places.

- 16)  $\pi(1+x)^2 - 5 = 2(1+x)$   
A)  $\{0.62, -1.98\}$       B)  $\{-0.62, 0.82\}$       C)  $\{-1.62, -0.62\}$       D)  $\{-0.62, -0.18\}$
- 17)  $x^{2/5} - 3x^{1/5} - 4 = 0$   
A)  $\{-1, 1024\}$       B)  $\{-1, 4\}$       C)  $\{-1, 1.32\}$       D)  $\{-1\}$

Solve the problem.

- 18) If  $k = \frac{x+3}{x-1}$  and  $k^2 - 5k = 6$ , find  $x$ .  
A)  $\left\{\frac{9}{5}, -1\right\}$       B)  $\left\{\frac{6}{5}, -1\right\}$       C)  $\left\{\frac{9}{5}, \frac{1}{2}\right\}$       D)  $\left\{\frac{3}{2}, -1\right\}$

### 3 Solve Absolute Value Equations

MULTIPLE CHOICE. Choose the one alternative that best completes the statement or answers the question.

Solve the equation.

- 1)  $|x| = 8$   
A)  $\{-8, 8\}$       B)  $\{8\}$       C)  $\{-8\}$       D)  $\{64\}$
- 2)  $|x| = -1$   
A)  $\{1\}$       B)  $\{1, -1\}$       C)  $\{-1\}$       D) no real solution
- 3)  $|x - 9| = 0$   
A)  $\{9\}$       B)  $\{-9, 9\}$       C)  $\{-9\}$       D) no real solution
- 4)  $|x + 6| = 9$   
A)  $\{-15, 3\}$       B)  $\{15, 3\}$       C)  $\{-3\}$       D) no real solution
- 5)  $|3x + 7| = 3$   
A)  $\left\{-\frac{4}{3}, -\frac{10}{3}\right\}$       B)  $\left\{-\frac{4}{7}, -\frac{10}{7}\right\}$       C)  $\left\{\frac{4}{3}, \frac{10}{3}\right\}$       D) no real solution
- 6)  $|2 - 4x| = 7$   
A)  $\left\{-\frac{5}{4}, \frac{9}{4}\right\}$       B)  $\left\{-\frac{3}{2}, \frac{11}{2}\right\}$       C)  $\left\{-\frac{9}{4}, \frac{5}{4}\right\}$       D)  $\left\{-\frac{11}{2}, \frac{3}{2}\right\}$
- 7)  $|-6x| = 5$   
A)  $\left\{-\frac{5}{6}, \frac{5}{6}\right\}$       B)  $\left\{-\frac{6}{5}, \frac{6}{5}\right\}$       C)  $\{-5, 5\}$       D) no real solution
- 8)  $|-x| = 11$   
A)  $\{-11, 11\}$       B)  $\{11\}$       C)  $\{-11\}$       D)  $\{121\}$
- 9)  $16 - |5x| = 9$   
A)  $\left\{-\frac{7}{5}, \frac{7}{5}\right\}$       B)  $\left\{-\frac{5}{7}, \frac{5}{7}\right\}$       C)  $\{-7, 7\}$       D) no real solution

$$10) \frac{2}{5}|x| = 9$$

$$A) \left\{ -\frac{45}{2}, \frac{45}{2} \right\}$$

$$B) \left\{ -\frac{18}{5}, \frac{18}{5} \right\}$$

$$C) \{-43, 43\}$$

D) no real solution

$$11) \left| \frac{x}{3} + \frac{1}{-4} \right| = 1$$

$$A) \left\{ -\frac{9}{4}, \frac{15}{4} \right\}$$

$$B) \left\{ -\frac{15}{4}, \frac{9}{4} \right\}$$

$$C) \left\{ \frac{15}{4} \right\}$$

D) no real solution

$$12) |u + 8| = -\frac{1}{2}$$

$$A) \left\{ -\frac{17}{2}, -\frac{15}{2} \right\}$$

$$B) \left\{ -\frac{17}{2} \right\}$$

$$C) \left\{ -\frac{15}{2} \right\}$$

D) no real solution

$$13) |x^2 - 16| = 0$$

$$A) \{-4, 4\}$$

$$B) \{-256, 256\}$$

$$C) \{4\}$$

$$D) \{-4\}$$

$$14) |x^2 + 6x| = 0$$

$$A) \{0, -6\}$$

$$B) \{6, 0, -6\}$$

$$C) \{6, 0\}$$

D) no real solution

$$15) |x^2 + 17x - 9| = 9$$

$$A) \{-18, -17, 0, 1\}$$

$$B) \{-18, 18, -1, 1\}$$

$$C) \{-18, -17, 1\}$$

$$D) \{-17, -1, 0, 18\}$$

#### 4 Solve Equations by Factoring

**MULTIPLE CHOICE.** Choose the one alternative that best completes the statement or answers the question.

**Find the real solutions of the equation by factoring.**

$$1) x^3 - 121x = 0$$

$$A) \{0, 11, -11\}$$

$$B) \{0, 11\}$$

$$C) \{0, -11\}$$

$$D) \{0, 121\}$$

$$2) 2x^5 = 72x^3$$

$$A) \{-6, 0, 6\}$$

$$B) \{-6\sqrt{2}, 0, 6\sqrt{2}\}$$

$$C) \{-6, 6\}$$

$$D) \{0\}$$

$$3) x^3 + 6x^2 - 4x - 24 = 0$$

$$A) \{-2, 2, -6\}$$

$$B) \{4, -6\}$$

$$C) \{2, -6\}$$

$$D) \{-2, 2, 6\}$$

$$4) x^3 + 5x^2 + 9x + 45 = 0$$

$$A) \{-5\}$$

$$B) \{5\}$$

$$C) \{-3, 3, -5\}$$

D) no real solution

$$5) 3x^4 - 243x^2 = 0$$

$$A) \{-9, 0, 9\}$$

$$B) \{-9\sqrt{3}, 0, 9\sqrt{3}\}$$

$$C) \{-9, 9\}$$

$$D) \{0\}$$

$$6) 4x^4 = 500x$$

$$A) \{0, 5\}$$

$$B) \{-5, 0, 5\}$$

$$C) \{0, 4, 5\}$$

$$D) \{0\}$$

$$7) x^3 + 9x^2 + 18x = 0$$

$$A) \{0, -6, -3\}$$

$$B) \{-6, -3\}$$

$$C) \{0, 6, 3\}$$

$$D) \{6, 3\}$$

8)  $x^3 + 4x^2 - x - 4 = 0$

A)  $\{-1, 1, -4\}$

B)  $\{1, -4, 4\}$

C)  $\{-4, 4\}$

D)  $\{16\}$

9)  $20x^3 + 100x^2 + 120x = 0$

A)  $\{0, -3, -2\}$

B)  $\{-3, -2\}$

C)  $\{0, 3, 2\}$

D)  $\{-\frac{1}{3}, -2\}$

## 1.6 Problem Solving: Interest, Mixture, Uniform Motion, Constant Rate Jobs

### 1 Translate Verbal Descriptions into Mathematical Expressions

**MULTIPLE CHOICE.** Choose the one alternative that best completes the statement or answers the question.

**Translate the sentence into a mathematical equation. Be sure to identify the meaning of all symbols.**

1) The surface area of a sphere is  $4\pi$  times the square of the radius.

A) If  $S$  represents the surface area and  $r$  the radius, then  $S = 4\pi r^2$ .

B) If  $S$  represents the surface area and  $r$  the radius, then  $S = 4\pi r$ .

C) If  $S$  represents the surface area and  $r$  the radius, then  $S = \pi r^2$ .

D) If  $S$  represents the surface area and  $r$  the radius, then  $4\pi S = r^2$ .

2) The volume of a right prism is the area of the base times the height of the prism.

A) If  $V$  represents the volume,  $B$  the area of the base, and  $h$  the height, then  $V = Bh$ .

B) If  $V$  represents the volume,  $B$  the area of the base, and  $h$  the height, then  $V = B + h$ .

C) If  $V$  represents the volume,  $B$  the area of the base, and  $h$  the height, then  $V = \frac{B}{h}$ .

D) If  $V$  represents the volume,  $B$  the area of the base, and  $h$  the height, then  $V = \frac{1}{2}Bh$ .

3) Speed is measured by distance divided by time.

A) If  $S$  represents speed,  $d$  distance, and  $t$  time, then  $S = \frac{d}{t}$ .

B) If  $S$  represents speed,  $d$  distance, and  $t$  time, then  $S = \frac{t}{d}$ .

C) If  $S$  represents speed,  $d$  distance, and  $t$  time, then  $d = \frac{S}{t}$ .

D) If  $S$  represents speed,  $d$  distance, and  $t$  time, then  $t = \frac{S}{d}$ .

4) Momentum is the product of the mass of an object and its velocity.

A) If  $M$  represents momentum,  $m$  mass, and  $v$  velocity, then  $M = mv$ .

B) If  $M$  represents momentum,  $m$  mass, and  $v$  velocity, then  $M = \frac{1}{2}mv$ .

C) If  $M$  represents momentum,  $m$  mass, and  $v$  velocity, then  $M = \frac{m}{v}$ .

D) If  $M$  represents momentum,  $m$  mass, and  $v$  velocity, then  $M = m + v$ .

- 5) The force of gravity between two objects is the gravitational constant times the product of their masses divided by the square of the distance between them.
- A) If  $F$  is the force of gravity,  $G$  the gravitational constant,  $m_1$  the mass of one object,  $m_2$  the mass of the second, and  $d$  the distance between them, then  $F = G \frac{m_1 m_2}{d^2}$ .
- B) If  $F$  is the force of gravity,  $G$  the gravitational constant,  $m_1$  the mass of one object,  $m_2$  the mass of the second, and  $d$  the distance between them, then  $FG = \frac{m_1 m_2}{d^2}$ .
- C) If  $F$  is the force of gravity,  $G$  the gravitational constant,  $m_1$  the mass of one object,  $m_2$  the mass of the second, and  $d$  the distance between them, then  $F = G \frac{m_1 m_2}{d}$ .
- D) If  $F$  is the force of gravity,  $G$  the gravitational constant,  $m_1$  the mass of one object,  $m_2$  the mass of the second, and  $d$  the distance between them, then  $F = G \frac{m_1 + m_2}{d^2}$ .
- 6) The total cost of producing refrigerators in one production line is \$3800 plus \$100 per unit produced.
- A) If  $C$  is the total cost and  $x$  is the number of units produced, then  $C = 3800 + 100x$ .
- B) If  $C$  is the total cost and  $x$  is the number of units produced, then  $C = 3800x + 100$ .
- C) If  $C$  is the total cost and  $x$  is the number of units produced, then  $C = (3800 + 100)x$ .
- D) If  $C$  is the total cost and  $x$  is the number of units produced, then  $C = \frac{3800}{100x}$ .
- 7) The profit derived from the sale of  $x$  video cameras is \$310 per unit less the sum of \$2100 costs plus \$170 per unit.
- A) If  $P$  is profit and  $x$  the units sold, then  $P = 310x - (2100 + 170x)$  or  $P = 140x - 2100$ .
- B) If  $P$  is profit and  $x$  the units sold, then  $P = 310x - (2100 - 170x)$  or  $P = 480x - 2100$ .
- C) If  $P$  is profit and  $x$  the units sold, then  $P = \frac{310}{x} - \left(2100 + \frac{170}{x}\right)$  or  $P = \frac{140}{x} - 2100$ .
- D) If  $P$  is profit and  $x$  the units sold, then  $P = 310x + 2100 - 170x$  or  $P = 140x + 2100$ .

## 2 Solve Interest Problems

**MULTIPLE CHOICE. Choose the one alternative that best completes the statement or answers the question.**

**Solve the problem.**

- 1) Don James wants to invest \$61,000 to earn \$5580 per year. He can invest in B-rated bonds paying 12% per year or in a Certificate of Deposit (CD) paying 6% per year. How much money should be invested in each to realize exactly \$5580 in interest per year?
- A) \$32,000 in B-rated bonds and \$29,000 in a CD      B) \$29,000 in B-rated bonds and \$32,000 in a CD  
 C) \$33,000 in B-rated bonds and \$28,000 in a CD      D) \$28,000 in B-rated bonds and \$33,000 in a CD
- 2) A bank loaned out \$52,000, part of it at the rate of 11% per year and the rest at a rate of 8% per year. If the interest received was \$5120, how much was loaned at 11%?
- A) \$32,000      B) \$20,000      C) \$33,000      D) \$19,000
- 3) A loan officer at a bank has \$92,000 to lend and is required to obtain an average return of 12% per year. If he can lend at the rate of 13% or the rate of 11%, how much can he lend at the 11% rate and still meet his required return?
- A) \$46,000.00      B) \$3833.33      C) \$1,150,000.00      D) \$7076.92

- 4) A college student earned \$7500 during summer vacation working as a waiter in a popular restaurant. The student invested part of the money at 9% and the rest at 7%. If the student received a total of \$597 in interest at the end of the year, how much was invested at 9%?  
 A) \$3600                      B) \$3900                      C) \$3750                      D) \$1071
- 5) Susan purchased some municipal bonds yielding 7% annually and some certificates of deposit yielding 9% annually. If Susan's investment amounts to \$19,000 and the annual interest is \$1590, how much money is invested in bonds and how much is invested in certificates of deposit?  
 A) \$6000 in bonds; \$13,000 in certificates of deposit  
 B) \$5500 in bonds; \$13,500 in certificates of deposit  
 C) \$13,000 in bonds; \$6000 in certificates of deposit  
 D) \$13,500 in bonds; \$5500 in certificates of deposit
- 6) Kevin invested part of his \$10,000 bonus in a certificate of deposit that paid 6% annual simple interest, and the remainder in a mutual fund that paid 11% annual simple interest. If his total interest for that year was \$700, how much did Kevin invest in the mutual fund?  
 A) \$2000                      B) \$8000                      C) \$3000                      D) \$1000

### 3 Solve Mixture Problems

**MULTIPLE CHOICE. Choose the one alternative that best completes the statement or answers the question.**

**Solve the problem.**

- 1) The manager of a coffee shop has one type of coffee that sells for \$6 per pound and another type that sells for \$15 per pound. The manager wishes to mix 30 pounds of the \$15 coffee to get a mixture that will sell for \$7 per pound. How many pounds of the \$6 coffee should be used?  
 A) 240 lb                      B) 120 lb                      C) 270 lb                      D) 135 lb
- 2) The owners of a candy store want to sell, for \$6 per pound, a mixture of chocolate-covered raisins, which usually sells for \$3 per pound, and chocolate-covered macadamia nuts, which usually sells for \$8 per pound. They have a 60-pound barrel of the raisins. How many pounds of the nuts should they mix with the barrel of raisins so that they hit their target value of \$6 per pound for the mixture?  
 A) 90 lb                      B) 84 lb                      C) 78 lb                      D) 96 lb
- 3) The manager of a candy shop sells chocolate covered peanuts for \$5 per pound and chocolate covered cashews for \$14 per pound. The manager wishes to mix 70 pounds of the cashews to get a cashew-peanut mixture that will sell for \$7 per pound. How many pounds of peanuts should be used?  
 A) 245 lb                      B) 122.5 lb                      C) 315 lb                      D) 157.5 lb
- 4) A chemist needs 140 milliliters of a 74% solution but has only 50% and 78% solutions available. Find how many milliliters of each that should be mixed to get the desired solution.  
 A) 20 mL of 50%; 120 mL of 78%                      B) 30 mL of 50%; 110 mL of 78%  
 C) 120 mL of 50%; 20 mL of 78%                      D) 110 mL of 50%; 30 mL of 78%
- 5) How much pure acid should be mixed with 3 gallons of a 50% acid solution in order to get an 80% acid solution?  
 A) 4.5 gal                      B) 1.5 gal                      C) 12 gal                      D) 7.5 gal
- 6) The radiator in a certain make of car needs to contain 50 liters of 40% antifreeze. The radiator now contains 50 liters of 20% antifreeze. How many liters of this solution must be drained and replaced with 100% antifreeze to get the desired strength?  
 A) 12.5 L                      B) 20 L                      C) 25 L                      D) 16.7 L

- 7) How many gallons of a 30% alcohol solution must be mixed with 60 gallons of a 14% solution to obtain a solution that is 20% alcohol?  
 A) 36 gal                      B) 27 gal                      C) 7 gal                      D) 12 gal
- 8) How many liters of 80% hydrochloric acid must be mixed with 40% hydrochloric acid to get 15 liters of 65% hydrochloric acid? Write your answer rounded to three decimals.  
 A) 9.375 L                      B) 3.125 L                      C) 4.688 L                      D) 8 L

#### 4 Solve Uniform Motion Problems

**MULTIPLE CHOICE. Choose the one alternative that best completes the statement or answers the question.**

**Solve the problem.**

- 1) An airplane flies 450 miles with the wind and 330 against the wind in the same length of time. If the speed of the wind is 30, what is the speed of the airplane in still air?  
 A) 195 mph                      B) 185 mph                      C) 200 mph                      D) 82.5 mph
- 2) A boat heads upstream a distance of 30 miles on the Mississippi river, whose current is running at 5 miles per hour. If the trip back takes an hour less, what was the speed of the boat in still water? Give the answer rounded to two decimal places, if necessary.  
 A) 18.03 mph                      B) 16.58 mph                      C) 6 mph                      D) 15 mph
- 3) Two friends decide to meet in Chicago to attend a Cub's baseball game. Rob travels 250 miles in the same time that Carl travels 220 miles. Rob's trip uses more interstate highways and he can average 6 mph more than Carl. What is Rob's average speed?  
 A) 50 mph                      B) 44 mph                      C) 54 mph                      D) 46 mph
- 4) Gary can hike on level ground 3 miles an hour faster than he can on uphill terrain. Yesterday, he hiked 36 miles, spending 2 hours on level ground and 5 hours on uphill terrain. Find his average speed on level ground.  
 A)  $7\frac{2}{7}$  mph                      B)  $4\frac{2}{7}$  mph                      C)  $5\frac{1}{7}$  mph                      D)  $7\frac{5}{7}$  mph
- 5) Two cars start from the same point and travel in the same direction. If one car is traveling 62 miles per hour and the other car is traveling at 56 miles per hour, how far apart will they be after 2.3 hours?  
 A) 13.8 mi                      B) 271.4 mi                      C) 142.6 mi                      D) 128.8 mi
- 6) Two trains leave a train station at the same time. One travels east at 11 miles per hour. The other train travels west at 12 miles per hour. In how many hours will the two trains be 144.9 miles apart?  
 A) 6.3 hr                      B) 12.6 hr                      C) 3.2 hr                      D) 6.8 hr
- 7) Ken and Kara are 31 miles apart on a calm lake paddling toward each other. Ken paddles at 3 miles per hour, while Kara paddles at 6 miles per hour. How long will it take them to meet?  
 A)  $3\frac{4}{9}$  hr                      B)  $3\frac{2}{3}$  hr                      C) 22 hr                      D)  $10\frac{1}{3}$  hr
- 8) A freight train leaves a station traveling at 32 km/h. Two hours later, a passenger train leaves the same station traveling in the same direction at 52 km/h. How long does it take the passenger train to catch up to the freight train?  
 A) 3.2 hr                      B) 4.2 hr                      C) 5.2 hr                      D) 2.2 hr

- 9) Five friends drove at an average rate of 50 miles per hour to a weekend retreat. On the way home, they took the same route but averaged 75 miles per hour. What was the distance between home and the retreat if the round trip took 10 hours?
- A) 300 mi                      B) 6 mi                      C) 1500 mi                      D) 600 mi
- 10) During a hurricane evacuation from the east coast of Georgia, a family traveled 300 miles west. For part of the trip, they averaged 50 mph, but as the congestion got bad, they had to slow to 10 mph. If the total time of travel was 9 hours, how many miles did they drive at the reduced speed?
- A) 37.5 mi                      B) 42.5 mi                      C) 47.5 mi                      D) 32.5 mi

## 5 Solve Constant Rate Job Problems

**MULTIPLE CHOICE.** Choose the one alternative that best completes the statement or answers the question.

**Solve the problem.**

- 1) An experienced bank auditor can check a bank's deposits twice as fast as a new auditor. Working together it takes the auditors 12 hours to do the job. How long would it take the experienced auditor working alone?
- A) 18 hr                      B) 36 hr                      C) 12 hr                      D) 24 hr
- 2) BJ can overhaul a boat's diesel inboard engine in 20 hours. His apprentice takes 60 hours to do the same job. How long would it take them working together assuming no gain or loss in efficiency?
- A) 15 hr                      B) 6 hr                      C) 80 hr                      D) 12 hr
- 3) Tracy can wallpaper 5 rooms in a new house in 40 hours. Together with her trainee they can wallpaper the 5 rooms in 23 hours. How long would it take the trainee working by herself to do the job?
- A) 55 hr                      B) 40 hr                      C) 95 hr                      D) 110 hr
- 4) Brandon can paint a fence in 12 hours and Elaine can paint the same fence in 11 hours. How long will they take to paint the fence if they work together?
- A)  $5\frac{17}{23}$  hr                      B)  $5\frac{13}{24}$  hr                      C)  $5\frac{3}{4}$  hr                      D)  $11\frac{1}{2}$  hr
- 5) Sue can sew a precut dress in 3 hours. Helen can sew the same dress in 2 hours. If they work together, how long will it take them to complete sewing that dress? Give your answer rounded to one decimal place, if necessary.
- A) 1.2 hr                      B) 5 hr                      C) 1.8 hr                      D) 2.5 hr

## 1.7 Solving Inequalities

### 1 Use Interval Notation

**MULTIPLE CHOICE.** Choose the one alternative that best completes the statement or answers the question.

Express the graph shown using interval notation. Also express it as an inequality involving  $x$ .

1)

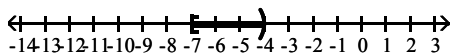

- A)  $[-7, -4]$                       B)  $(-7, -4)$                       C)  $[-7, -4]$                       D)  $(-7, -4]$   
 $-7 \leq x < -4$                        $-7 < x < -4$                        $-7 \leq x \leq -4$                        $-7 < x \leq -4$

2)

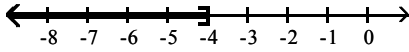

A)  $(-\infty, -4]$   
 $x \leq -4$

B)  $(-\infty, -4)$   
 $x < -4$

C)  $[-4, \infty)$   
 $x \geq -4$

D)  $(-4, \infty)$   
 $x > -4$

3)

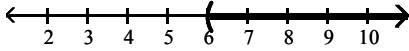

A)  $(6, \infty)$   
 $x > 6$

B)  $(-\infty, 6]$   
 $x \leq 6$

C)  $[6, \infty)$   
 $x \geq 6$

D)  $(-\infty, 6)$   
 $x < 6$

4)

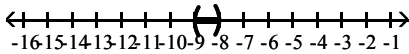

A)  $(-9, -8)$   
 $-9 < x < -8$

B)  $[-9, -8]$   
 $-9 \leq x \leq -8$

C)  $(-9, -8]$   
 $-9 < x \leq -8$

D)  $[-9, -8)$   
 $-9 \leq x < -8$

5)

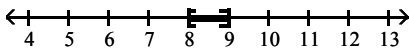

A)  $[8, 9]$   
 $8 \leq x \leq 9$

B)  $(8, 9)$   
 $8 < x < 9$

C)  $[8, 9)$   
 $8 \leq x < 9$

D)  $(8, 9]$   
 $8 < x \leq 9$

6)

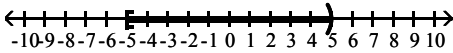

A)  $[-5, 5)$   
 $-5 \leq x < 5$

B)  $(-5, 5]$   
 $-5 < x \leq 5$

C)  $(-\infty, 5)$   
 $x < 5$

D)  $[-5, 5]$   
 $-5 \leq x \leq 5$

Write the inequality using interval notation, and illustrate the inequality using the real number line.

7)  $1 < x < 8$

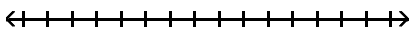

A)  $(1, 8)$

B)  $[1, 8]$

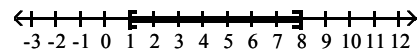
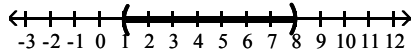

C)  $(1, 8)$

D)  $[1, 8]$

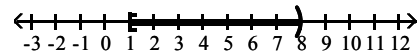
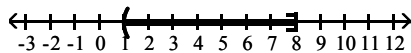



8)  $-8 \leq x \leq -4$

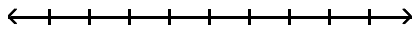

A)  $[-8, -4]$

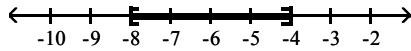

C)  $[-8, -4]$

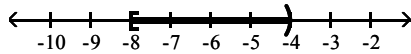

B)  $(-8, -4)$

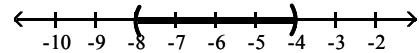

D)  $(-8, -4)$

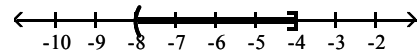

9)  $-1 \leq x < 5$

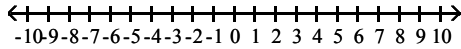

A)  $[-1, 5]$

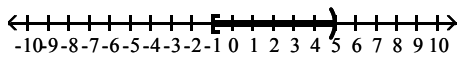

C)  $(-\infty, 5)$

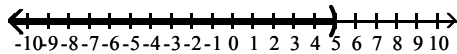

B)  $(-1, 5]$

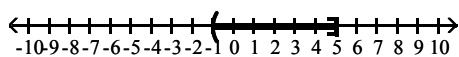

D)  $[-1, 5]$

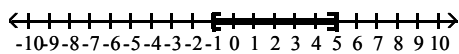

10)  $t \geq -7$

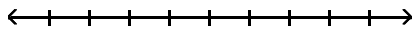

A)  $[-7, \infty)$

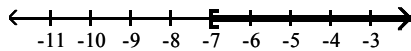

C)  $(-7, \infty)$

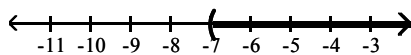

B)  $[-7, \infty]$

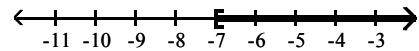

D)  $(-7, \infty]$

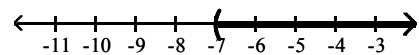

11)  $y < -6$

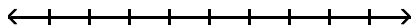

A)  $(-\infty, -6)$

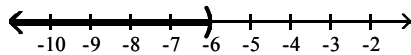

C)  $[-\infty, -6]$

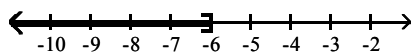

B)  $(-\infty, -6]$

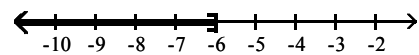

D)  $[-\infty, -6)$

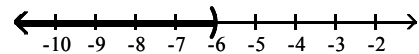

Write the interval as an inequality involving  $x$ , and illustrate the inequality using the real number line.

12)  $[-9, 2)$

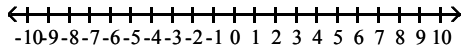

A)  $-9 \leq x < 2$

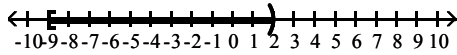

C)  $x < 2$

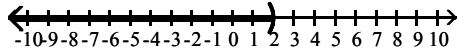

B)  $-9 < x \leq 2$

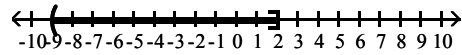

D)  $-9 \leq x < 2$

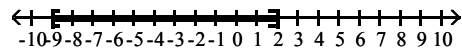

13)  $[-7, 9]$

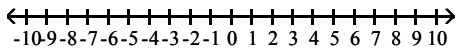

A)  $-7 \leq x \leq 9$

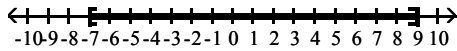

C)  $-7 < x < 9$

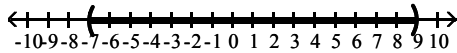

B)  $-7 < x \leq 9$

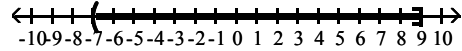

D)  $-7 \leq x < 9$

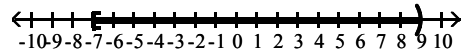

14)  $(0, \infty)$

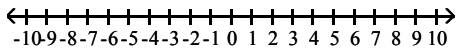

A)  $x > 0$

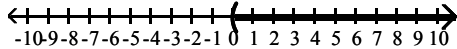

C)  $x > 0$

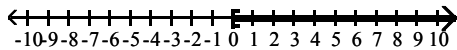

B)  $x \geq 0$

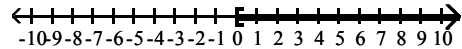

D)  $x \geq 0$

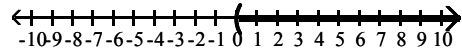

15)  $[-6, \infty)$

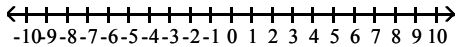

A)  $x \geq -6$

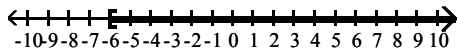

C)  $x > -6$

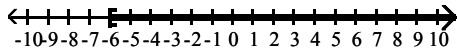

B)  $x > -6$

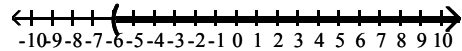

D)  $x \geq -6$

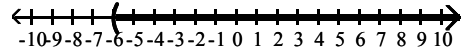

16)  $(-\infty, 4)$

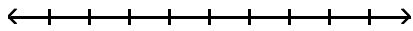

A)  $x < 4$

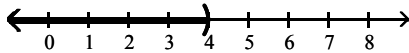

C)  $x < 4$

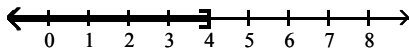

B)  $x \leq 4$

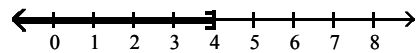

D)  $x \leq 4$

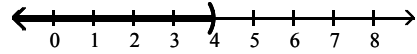

## 2 Use Properties of Inequalities

**MULTIPLE CHOICE.** Choose the one alternative that best completes the statement or answers the question.

**Write the inequality obtained by performing the indicated operation on the given inequality.**

1) Add 5 to each side of the inequality  $2 + 4x > 3$ .

A)  $7 + 4x > 8$

B)  $7 + 4x < 8$

C)  $7 + 9x > 8$

D)  $7 + 9x < 8$

2) Multiply each side of the inequality  $3 + 2x \geq 5$  by  $-2$ .

A)  $-6 - 4x \leq -10$

B)  $-6 - 4x \geq -10$

C)  $-6 + 2x \leq -10$

D)  $-6 + 2x \geq -10$

**Fill in the blank with the correct inequality symbol.**

3) If  $x < 14$ , then  $x - 14$  \_\_\_\_ 0.

A)  $<$

B)  $>$

C)  $\leq$

D)  $\geq$

4) If  $x < -12$ , then  $x + 12$  \_\_\_\_ 0.

A)  $<$

B)  $>$

C)  $\leq$

D)  $\geq$

5) If  $x > -5$ , then  $5x$  \_\_\_\_  $-25$ .

A)  $>$

B)  $<$

C)  $\geq$

D)  $\leq$

6) If  $x < 4$ , then  $-2x$  \_\_\_\_  $-8$ .

A)  $>$

B)  $<$

C)  $\geq$

D)  $\leq$

7) If  $x > -8$ , then  $-6x$  \_\_\_\_  $48$ .

A)  $<$

B)  $>$

C)  $\geq$

D)  $\leq$

8) If  $-3x > -3$ , then  $x$  \_\_\_\_  $1$ .

A)  $<$

B)  $>$

C)  $\geq$

D)  $\leq$

### 3 Solve Linear Inequalities Algebraically and Graphically

MULTIPLE CHOICE. Choose the one alternative that best completes the statement or answers the question.

Solve the inequality. Express your answer using interval notation. Graph the solution set.

1)  $x - 3 < 4$

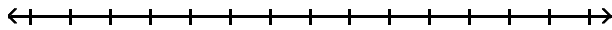

A)  $(-\infty, 7)$

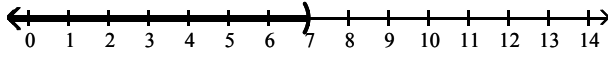

B)  $(7, \infty)$



C)  $(-\infty, 1)$

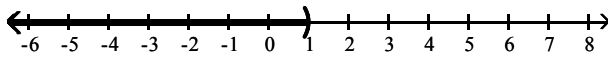

D)  $(-\infty, 1]$

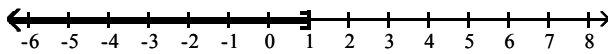

2)  $x - 3 < 4$

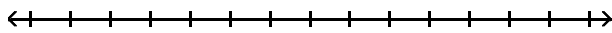

A)  $(-\infty, 7)$

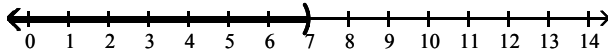

B)  $(7, \infty)$

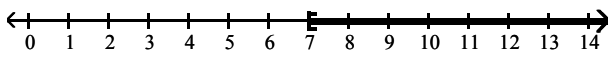

C)  $(-\infty, 1)$

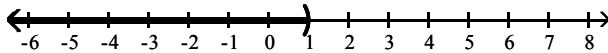

D)  $(-\infty, 7]$

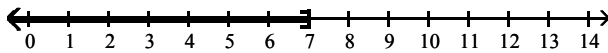

3)  $3x + 5 < 26$

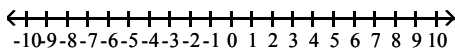

A)  $(-\infty, 7)$

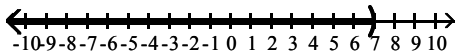

B)  $(7, \infty)$

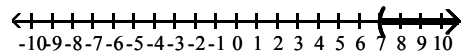

C)  $[7, \infty)$

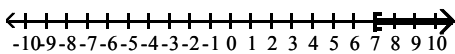

D)  $(-\infty, 7]$

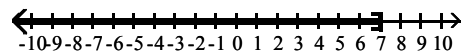

4)  $5x + 4 > 4x - 1$

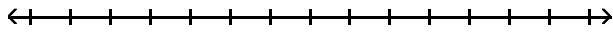

A)  $(-5, \infty)$

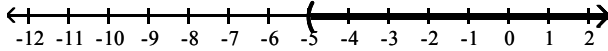

B)  $(-\infty, -5]$

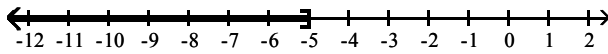

C)  $(3, \infty)$

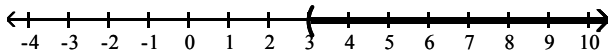

D)  $[-5, \infty)$

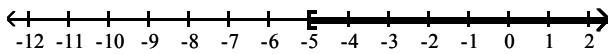

5)  $-2x - 6 \leq -3x - 1$

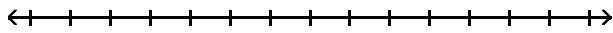

A)  $(-\infty, 5]$

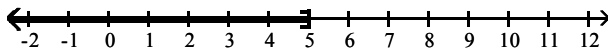

B)  $(-\infty, 5)$

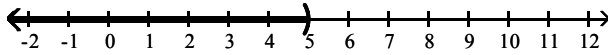

C)  $[5, \infty)$

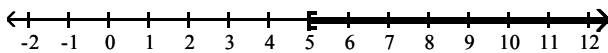

D)  $[-7, \infty)$

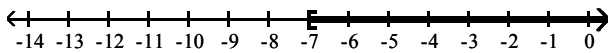

6)  $4x - 2 \geq 3x - 3$

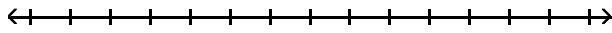

A)  $[-1, \infty)$

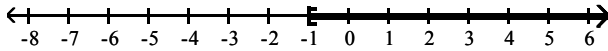

B)  $(-\infty, -1)$

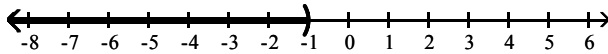

C)  $(-\infty, -1]$

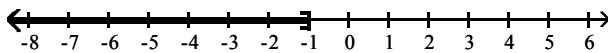

D)  $(-5, \infty)$

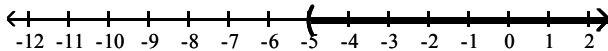

7)  $-5x - 5 > -6x - 8$

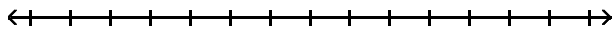

A)  $(-3, \infty)$

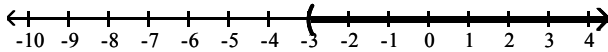

B)  $(-\infty, -3]$

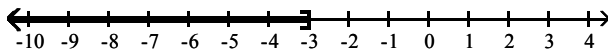

C)  $(-13, \infty)$

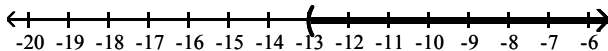

D)  $[-3, \infty)$

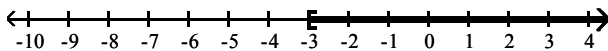

8)  $8 - 2(3 - x) \leq 8$

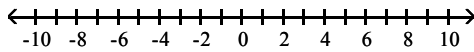

A)  $(-\infty, 3]$

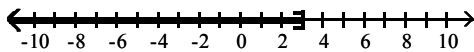

C)  $(-\infty, 4]$

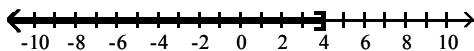

B)  $[3, \infty)$

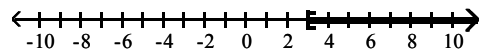

D)  $(-\infty, 3)$

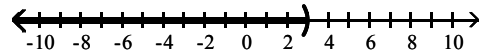

9)  $-12x + 10 \leq -2(5x - 2)$

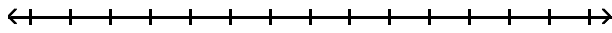

A)  $[3, \infty)$

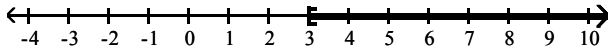

B)  $(-\infty, 3]$

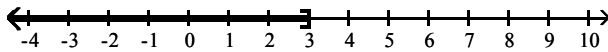

C)  $[3, \infty)$

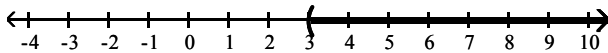

D)  $(-\infty, 3)$

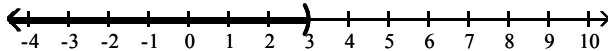

10)  $-2(6x + 7) < -14x - 12$

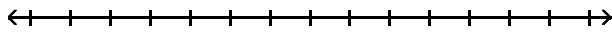

A)  $(-\infty, 1)$

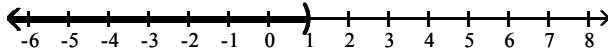

B)  $(1, \infty)$

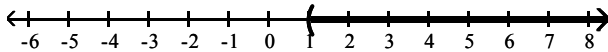

C)  $(-\infty, 1]$

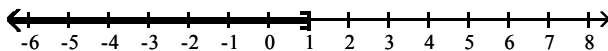

D)  $(-\infty, 13]$

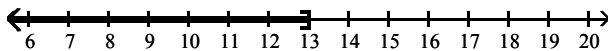

11)  $\frac{x}{3} \geq 4 + \frac{x}{15}$

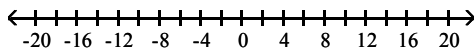

A)  $[15, \infty)$

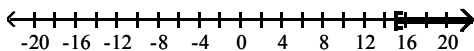

B)  $[-15, \infty)$

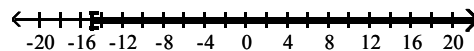

C)  $(-\infty, 15]$

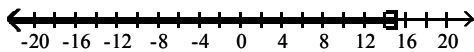

D)  $(15, \infty)$

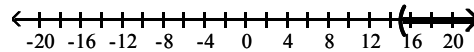

12)  $x(25x + 4) \leq (5x + 7)^2$

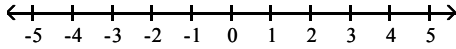

A)  $\left[-\frac{49}{66}, \infty\right)$

B)  $\left(-\infty, -\frac{49}{66}\right]$

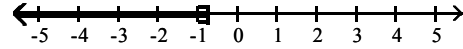
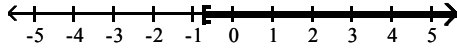

C)  $\left[\frac{49}{66}, \infty\right)$

D)  $\left(-\infty, \frac{49}{66}\right]$

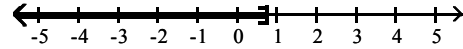
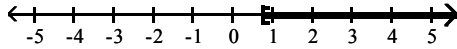

**Solve the problem.**

- 13) During the first five months of the year, Len earned commissions of \$3160, \$2810, \$3140, \$2800, and \$2380. If Len must have average monthly earnings of at least \$2780 in order to qualify for retirement benefits, what must he earn in the sixth month in order to qualify for benefits?  
 A) at least \$2390                      B) at least \$2845                      C) at least \$2780                      D) at least \$2858
- 14) Jim has gotten scores of 69 and 66 on his first two tests. What score must he get on his third test to keep an average of 70 or better?  
 A) at least 75                              B) at least 67.5                              C) at least 68                              D) at least 73
- 15) At Bargain Car Rental, the cost of renting an economy car for one day is \$19.95 plus 20 cents per mile. At Best Deal Car Rental, the cost of renting a similar car for one day is \$24.95 plus 15 cents per mile. Solve the inequality  $24.95 + 0.15x < 19.95 + 0.20x$  to find the range of miles driven such that Best Deal is a better deal than Bargain.  
 A)  $x > 100$  mi                              B)  $x < 100$  mi                              C)  $x > 10$  mi                              D)  $x < 10$  mi



#### 4 Solve Combined Inequalities Algebraically and Graphically

**MULTIPLE CHOICE.** Choose the one alternative that best completes the statement or answers the question.

Solve the inequality. Express your answer using interval notation. Graph the solution set.

1)  $8 < 2x \leq 10$

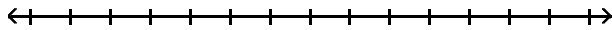

A)  $(4, 5]$

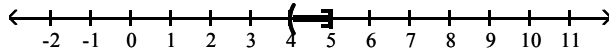

B)  $[4, 5)$

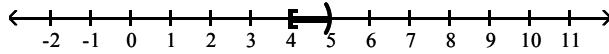

C)  $(-5, -4]$

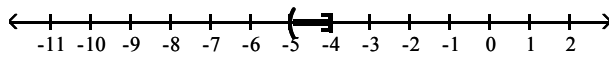

D)  $[-5, -4)$

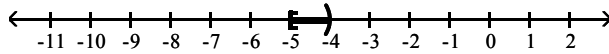

2)  $-5 < x + 1 \leq 6$

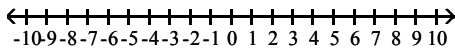

A)  $(-6, 5]$

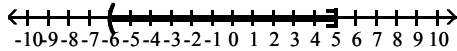

B)  $(-4, 7]$

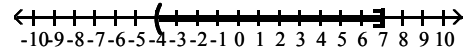

C)  $[-6, 5)$

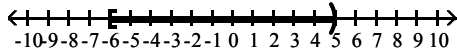

D)  $[-4, 7)$

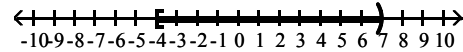

3)  $3 \leq 2x - 1 \leq 11$

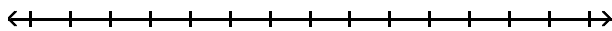

A)  $[2, 6]$

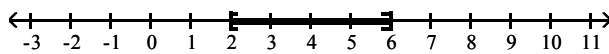

B)  $(2, 6)$

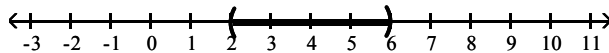

C)  $[-6, -2]$

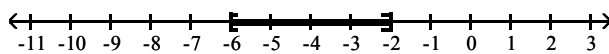

D)  $(-6, -2)$

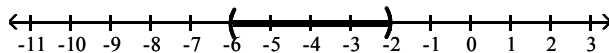

4)  $-15 \leq -2x - 1 < -7$

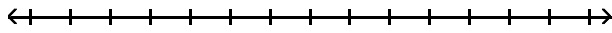

A)  $(3, 7]$

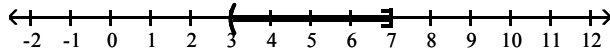

B)  $[3, 7)$

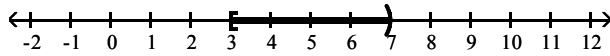

C)  $[-7, -3)$

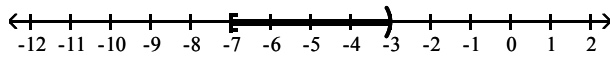

D)  $(-7, -3]$

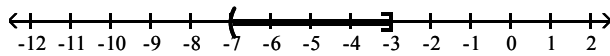

5)  $-21 \leq -3x - 3 \leq -12$

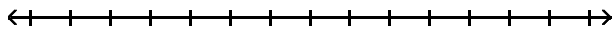

A)  $[3, 6]$

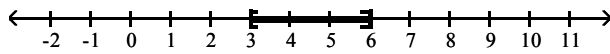

B)  $(3, 6)$

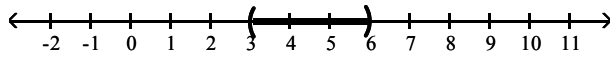

C)  $[-6, -3]$

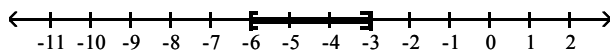

D)  $(-6, -3)$

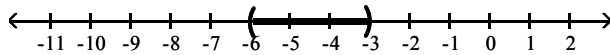

6)  $0 \leq \frac{2x + 5}{3} < 3$

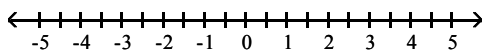

A)  $\left[-\frac{5}{2}, 2\right]$

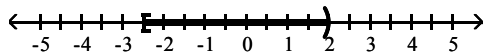

C)  $\left[-\frac{5}{2}, 2\right)$

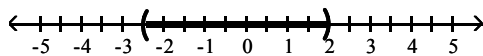

B)  $\left[-\frac{5}{2}, 2\right)$

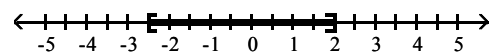

D)  $\left[-\frac{5}{2}, 2\right]$

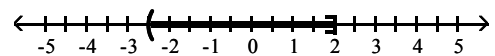

$$7) 5 \leq \frac{3}{2}x + 2 < 14$$

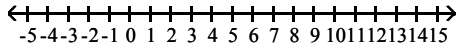

A)  $[2, 8]$

B)  $(2, 8]$

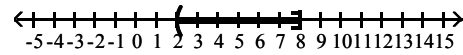
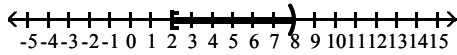

C)  $[2, 3]$

D)  $(2, 3]$

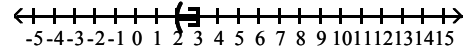
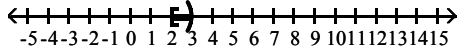

$$8) -\frac{1}{3} \leq \frac{6x - 1}{9} < \frac{1}{3}$$

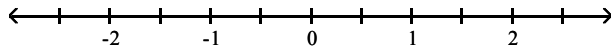

A)  $\left[-\frac{1}{3}, \frac{2}{3}\right]$

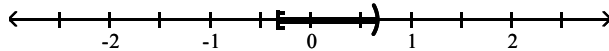

B)  $\left[-\frac{4}{9}, \frac{5}{9}\right]$

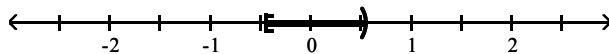

C)  $\left[-\frac{1}{3}, \frac{2}{3}\right)$

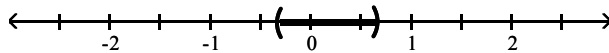

D)  $\left[-\frac{1}{3}, \frac{2}{3}\right)$

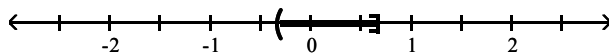

**Solve the problem.**

9) In one city, the local cable TV company charges \$3.10 for each pay-per-view movie watched. In addition, each monthly bill contains a basic customer charge of \$25.50. If last month's bills ranged from a low of \$31.70 to a high of \$72.00, over what range did customers watch pay-per-view movies?

- A) movies watched varied from 2 to 15 inclusive      B) movies watched varied from 1 to 14 inclusive  
 C) movies watched varied from 3 to 16 inclusive      D) movies watched varied from 1 to 16 inclusive

10) A real estate agent agrees to sell an office building according to the following commission schedule: \$36,000 plus 30% of the selling price in excess of \$700,000. Assuming that the office building will sell at some price between \$700,000 and \$1,000,000, inclusive, over what range does the agent's commission vary?

- A) The commission will vary between \$36,000 and \$126,000, inclusive.  
 B) The commission will vary between \$37,000 and \$126,000, inclusive.  
 C) The commission will vary between \$36,000 and \$326,000, inclusive.  
 D) The commission will vary between \$246,000 and \$336,000, inclusive.

- 11) In his algebra class, Rob has scores of 79, 85, 81, and 65 on his first four tests. To get a grade of C, the average of the first five tests must be greater than or equal to 70 and less than 80. Solve an inequality to find the range of scores that Rob can earn on the fifth test to get a C.
- A)  $40 \leq x < 90$ , where  $x$  represents Bob's score on the fifth test
  - B)  $40 < x < 90$ , where  $x$  represents Bob's score on the fifth test
  - C)  $40 \leq x \leq 90$ , where  $x$  represents Bob's score on the fifth test
  - D)  $x \geq 40$ , where  $x$  represents Bob's score on the fifth test
- 12) Marianne is planning a shopping trip to buy birthday gifts for her son. She estimates that the total price of the items she plans to purchase will be between \$350 and \$400 inclusive. If sales are taxed at a rate of 8.375% in her area, what is the range of the amount of sales tax she should expect to pay on her purchases? If Marianne's budget for the shopping trip is \$425, will she necessarily be able to buy all the gifts that she has planned?
- A)  $\$29.31 \leq x \leq \$33.50$ , where  $x$  represents the amount of sales tax; No.
  - B)  $\$29.31 \leq x \leq \$33.50$ , where  $x$  represents the amount of sales tax; Yes.
  - C)  $\$29.31 < x < \$33.50$ , where  $x$  represents the amount of sales tax; No.
  - D)  $\$29.31 < x < \$33.50$ , where  $x$  represents the amount of sales tax; Yes.

## 5 Solve Absolute Value Inequalities Algebraically and Graphically

**MULTIPLE CHOICE.** Choose the one alternative that best completes the statement or answers the question.

Solve the inequality. Express your answer using interval notation. Graph the solution set.

1)  $|x| < 3$

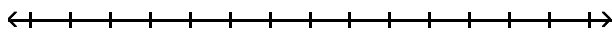

A)  $(-3, 3)$

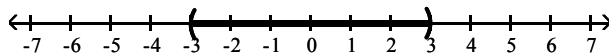

B)  $(-\infty, 3]$

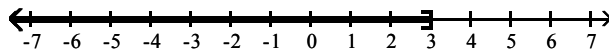

C)  $(-\infty, -3) \cup (3, \infty)$

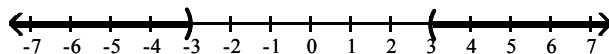

D)  $[-3, 3]$

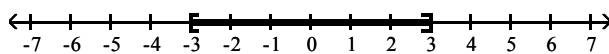

2)  $|x| > 4$

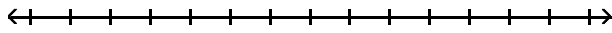

A)  $(-\infty, -4) \cup (4, \infty)$

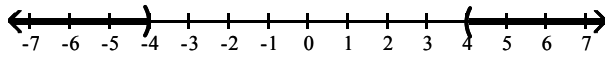

B)  $[4, \infty)$

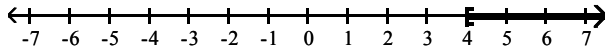

C)  $(-4, 4)$

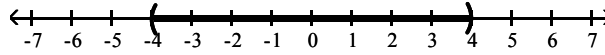

D)  $[-4, 4]$

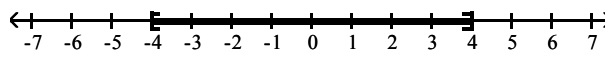

3)  $|x| > -2$

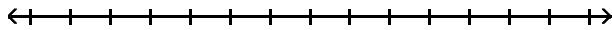

A)  $(-2, 2)$

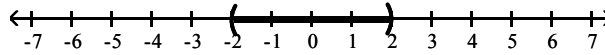

B)  $[-2, \infty)$

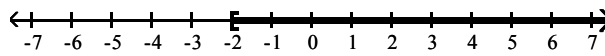

C)  $(-\infty, -2) \cup (2, \infty)$

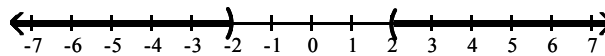

D)  $(-\infty, \infty)$

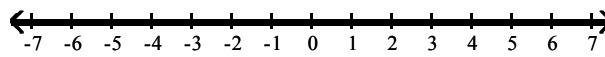

4)  $|x| < -4$

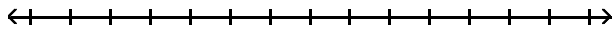

A)  $(-4, 4)$

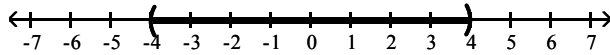

B)  $(-\infty, -4]$

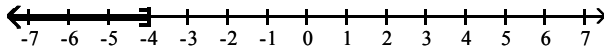

C)  $(-\infty, -4) \cup (4, \infty)$

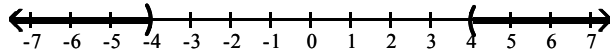

D)  $\emptyset$

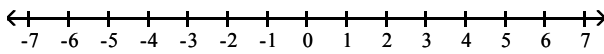

5)  $|6x| < 54$

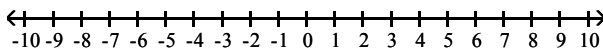

A)  $(-9, 9)$

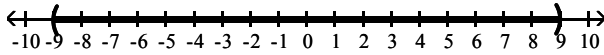

B)  $(-\infty, 9)$

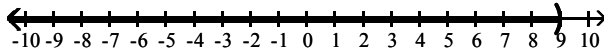

C)  $(-\infty, -9) \cup (9, \infty)$

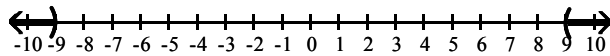

D)  $(-9, 9)$

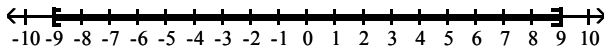

6)  $|4x| > 16$

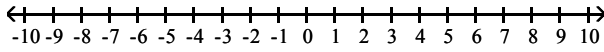

A)  $(-\infty, -4) \cup (4, \infty)$

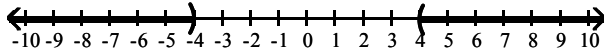

B)  $(4, \infty)$

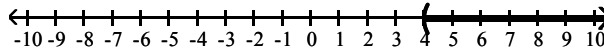

C)  $(-4, 4)$

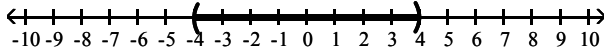

D)  $(-\infty, -4] \cup [4, \infty)$

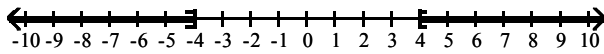

7)  $|x - 10| < 5$

A)  $(5, 15)$

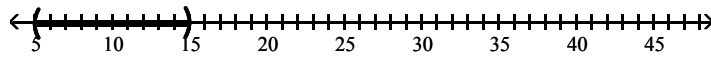

B)  $(-15, -5)$

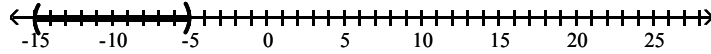

C)  $(-\infty, 15)$

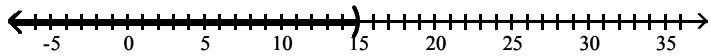

D)  $(-\infty, 5)$

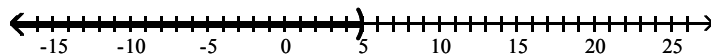

8)  $|x - 2| > 3$

A)  $(-\infty, -1) \cup (5, \infty)$

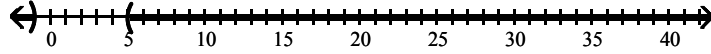

B)  $(-5, 1)$

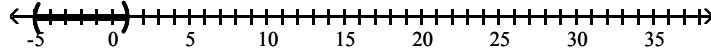

C)  $(-1, 5)$

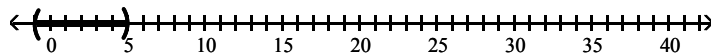

D)  $(5, \infty)$

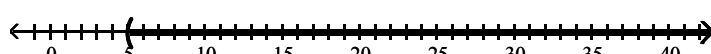

9)  $|5k - 7| \geq 6$

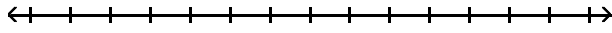

A)  $\left(-\infty, \frac{1}{5}\right] \cup \left[\frac{13}{5}, \infty\right)$

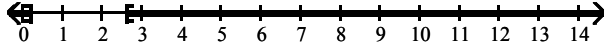

B)  $\left[\frac{1}{5}, \frac{13}{5}\right]$

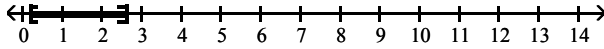

C)  $\left(\frac{1}{5}, \frac{13}{5}\right)$

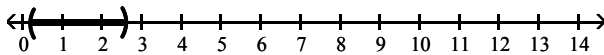

D)  $\left[\frac{13}{5}, \infty\right)$

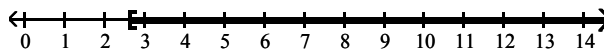

10)  $|4k - 9| \leq 8$

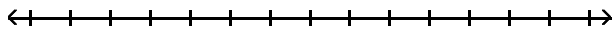

A)  $\left[\frac{1}{4}, \frac{17}{4}\right]$

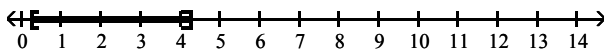

B)  $\left(-\infty, \frac{1}{4}\right] \cup \left[\frac{17}{4}, \infty\right)$

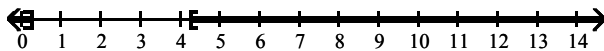

C)  $\left(\frac{1}{4}, \frac{17}{4}\right)$

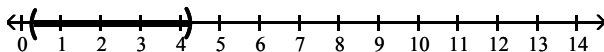

D)  $\left(-\infty, \frac{17}{4}\right]$

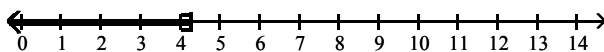



11)  $|x + 5| - 6 \leq 0$

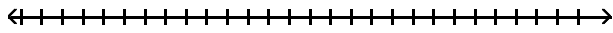

A)  $[-11, 1]$

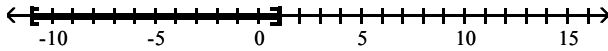

B)  $(-11, 1)$

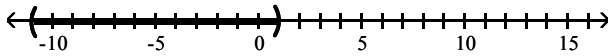

C)  $[-11, 0]$

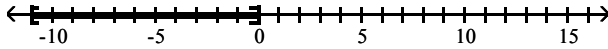

D)  $\emptyset$

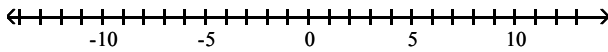

12)  $|x + 8| + 4 \geq 7$

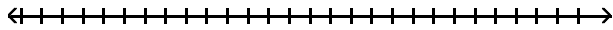

A)  $(-\infty, -11] \cup [-5, \infty)$

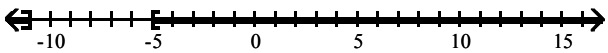

B)  $[-11, -5]$

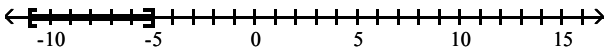

C)  $(-11, -5)$

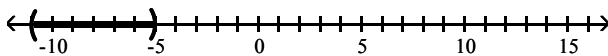

D)  $[-5, \infty)$

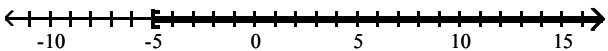

13)  $|8k + 8| - 2 > 7$

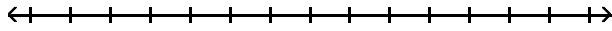

A)  $\left(-\infty, -\frac{17}{8}\right) \cup \left(\frac{1}{8}, \infty\right)$

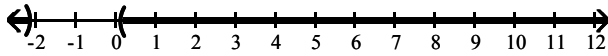

B)  $\left(-\frac{17}{8}, \frac{1}{8}\right)$

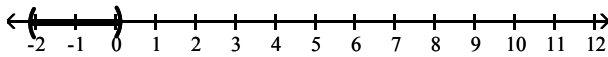

C)  $\left(-\infty, -\frac{17}{8}\right] \cup \left[\frac{1}{8}, \infty\right)$

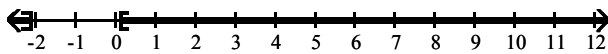

D)  $\left(\frac{1}{8}, \infty\right)$

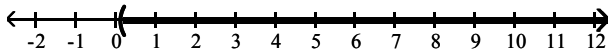

14)  $|3k + 7| - 5 < 1$

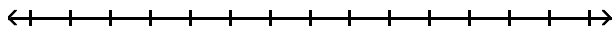

A)  $\left(-\frac{13}{3}, -\frac{1}{3}\right)$

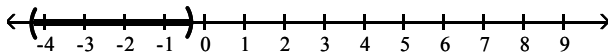

B)  $\left(-\infty, -\frac{13}{3}\right) \cup \left(-\frac{1}{3}, \infty\right)$

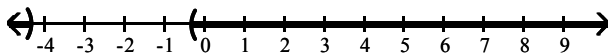

C)  $\left(-\infty, -\frac{13}{3}\right)$

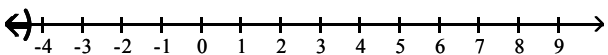

D)  $\left(-\infty, -\frac{1}{3}\right)$

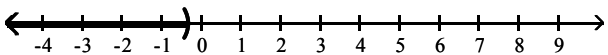

15)  $|x - 5| \geq 0$

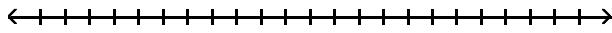

A) 5

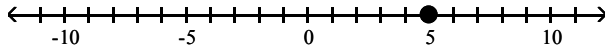

B)  $(-\infty, -5) \cup (-5, \infty)$

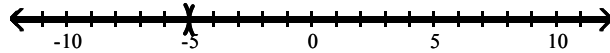

C)  $(-\infty, 5) \cup (5, \infty)$

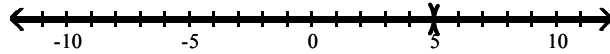

D)  $(-\infty, \infty)$

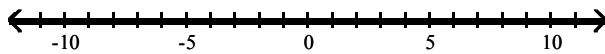

**Solve the problem.**

16) Express the fact that  $x$  differs from  $-7$  by more than 3 as an inequality involving absolute value. Solve for  $x$ .

A)  $|x + 7| > 3; \{x | x < -10 \text{ or } x > -4\}$

B)  $|x + 7| > 3; \{x | -10 < x < -4\}$

C)  $|x + 7| < 3; \{x | -10 < x < -4\}$

D)  $|x + 7| < 3; \{x | x < -10 \text{ or } x > -4\}$

17) A landscaping company sells 40-pound bags of top soil. The actual weight  $x$  of a bag, however, may differ from the advertised weight by as much as 0.75 pound. Write an inequality involving absolute value that expresses the relationship between the actual weight  $x$  of a bag and 40 pounds. Over what range may the weight of a 40-pound bag of top soil vary?

A)  $|x - 40| \leq 0.75; \{x | 39.25 \leq x \leq 40.75\}$

B)  $|x - 40| < 0.75; \{x | 39.25 < x < 40.75\}$

C)  $|x - 40| \geq 0.75; \{x | x \leq 39.25 \text{ or } x \geq 40.75\}$

D)  $|x - 40| \geq 0.75; \{x | 39.25 \leq x \leq 40.75\}$

## Ch. 1 Graphs, Equations, and Inequalities

### Answer Key

#### 1.1 The Distance and Midpoint Formulas; Graphing Utilities; Introduction to Graphing Equations

##### 1 Use the Distance Formula

- 1) A
- 2) A
- 3) A
- 4) A
- 5) A
- 6) A
- 7) A
- 8) A
- 9) A
- 10) A
- 11) A
- 12) A
- 13) A
- 14) A
- 15) B
- 16) B
- 17) A
- 18) A
- 19) A
- 20) A
- 21) A
- 22) A
- 23) A

##### 2 Use the Midpoint Formula

- 1) A
- 2) A
- 3) A
- 4) A
- 5) A
- 6) A
- 7) A
- 8) A
- 9) A
- 10) A
- 11) A

##### 3 Graph Equations by Plotting Points

- 1) A
- 2) A
- 3) A
- 4) A
- 5) A
- 6) A
- 7) A
- 8) A
- 9) A
- 10) A
- 11) A
- 12) A

13) A

**4 Graph Equations Using a Graphing Utility**

- 1) A
- 2) A
- 3) A
- 4) A
- 5) A
- 6) A
- 7) A

**5 Use a Graphing Utility to Create Tables**

- 1) A
- 2) A
- 3) A
- 4) A

**6 Find Intercepts from a Graph**

- 1) A
- 2) A
- 3) A
- 4) A
- 5) A
- 6) A
- 7) A
- 8) A

**7 Use a Graphing Utility to Approximate Intercepts**

- 1) A
- 2) A
- 3) A
- 4) A
- 5) A
- 6) A
- 7) A
- 8) A

**1.2 Solving Equations Using a Graphing Utility; Linear and Rational Equations**

**1 Solve Equations Using a Graphing Utility**

- 1) A
- 2) D
- 3) A
- 4) A
- 5) A

**2 Solve Linear Equations**

- 1) A
- 2) A
- 3) A
- 4) A
- 5) A
- 6) A
- 7) A
- 8) A
- 9) A
- 10) A
- 11) A
- 12) A

- 13) A
- 14) A
- 15) A
- 16) A
- 17) C
- 18) A
- 19) D
- 20) A
- 21) A
- 22) A
- 23) A
- 24) A
- 25) A
- 26) A
- 27) A
- 28) A
- 29) A
- 30) A
- 31) A
- 32) A
- 33) A
- 34) A

### 3 Solve Rational Equations

- 1) A
- 2) A
- 3) A
- 4) A
- 5) A
- 6) D
- 7) A
- 8) A
- 9) A
- 10) A
- 11) A
- 12) A
- 13) A
- 14) A
- 15) D
- 16) A

### 4 Solve Problems That Can Be Modeled by Linear Equations

- 1) A
- 2) A
- 3) A
- 4) A
- 5) A
- 6) A
- 7) A
- 8) A
- 9) A
- 10) A
- 11) A
- 12) A
- 13) A

- 14) A
- 15) A
- 16) A
- 17) A
- 18) A
- 19) A

### 1.3 Quadratic Equations

#### 1 Solve Quadratic Equations by Factoring

- 1) A
- 2) A
- 3) A
- 4) A
- 5) A
- 6) A
- 7) A
- 8) A
- 9) A
- 10) A
- 11) A
- 12) A
- 13) A
- 14) A
- 15) A
- 16) A

#### 2 Solve Quadratic Equations Using the Square Root Method

- 1) A
- 2) A
- 3) A
- 4) A
- 5) A
- 6) A
- 7) A
- 8) A

#### 3 Solve Quadratic Equations by Completing the Square

- 1) A
- 2) A
- 3) A
- 4) A
- 5) A
- 6) A
- 7) A
- 8) A
- 9) A
- 10) A
- 11) A
- 12) A
- 13) A
- 14) A
- 15) A

#### 4 Solve Quadratic Equations Using the Quadratic Formula

- 1) A
- 2) A

- 3) D
- 4) A
- 5) D
- 6) A
- 7) A
- 8) A
- 9) A
- 10) A
- 11) A
- 12) A
- 13) D
- 14) A
- 15) B
- 16) A
- 17) C
- 18) C
- 19) B

**5 Solve Problems That Can Be Modeled by Quadratic Equations**

- 1) A
- 2) A
- 3) A
- 4) A
- 5) A
- 6) A
- 7) A
- 8) A
- 9) A
- 10) A
- 11) A
- 12) A
- 13) A

**1.4 Complex Numbers; Quadratic Equations in the Complex Number System**

**1 Add, Subtract, Multiply, and Divide Complex Numbers**

- 1) A
- 2) A
- 3) A
- 4) A
- 5) A
- 6) A
- 7) A
- 8) A
- 9) A
- 10) A
- 11) A
- 12) A
- 13) A
- 14) A
- 15) A
- 16) A
- 17) A
- 18) A
- 19) A



- 20) A
- 21) A
- 22) A
- 23) A
- 24) A
- 25) A
- 26) A
- 27) A
- 28) A
- 29) A
- 30) A
- 31) A
- 32) A
- 33) A
- 34) A
- 35) A
- 36) A
- 37) A
- 38) A

**2 Solve Quadratic Equations in the Complex Number System**

- 1) A
- 2) A
- 3) A
- 4) A
- 5) A
- 6) A
- 7) A
- 8) B
- 9) A
- 10) C
- 11) C
- 12) B
- 13) A
- 14) A
- 15) A

**1.5 Radical Equations; Equations Quadratic in Form; Absolute Value Equations; Factorable Equations**

**1 Solve Radical Equations**

- 1) A
- 2) A
- 3) A
- 4) A
- 5) A
- 6) A
- 7) A
- 8) A
- 9) A
- 10) A
- 11) A
- 12) A
- 13) A
- 14) A

- 15) A
- 16) A
- 17) D
- 18) A
- 19) A
- 20) A
- 21) A
- 22) A
- 23) A
- 24) A
- 25) A
- 26) A
- 27) A
- 28) A
- 29) A
- 30) A
- 31) A
- 32) A
- 33) A

**2 Solve Equations Quadratic in Form**

- 1) A
- 2) A
- 3) A
- 4) A
- 5) A
- 6) A
- 7) A
- 8) D
- 9) A
- 10) A
- 11) A
- 12) A
- 13) A
- 14) A
- 15) A
- 16) A
- 17) A
- 18) A

**3 Solve Absolute Value Equations**

- 1) A
- 2) D
- 3) A
- 4) A
- 5) A
- 6) A
- 7) A
- 8) A
- 9) A
- 10) A
- 11) A
- 12) D
- 13) A
- 14) A

15) A

**4 Solve Equations by Factoring**

1) A

2) A

3) A

4) A

5) A

6) A

7) A

8) A

9) A

**1.6 Problem Solving: Interest, Mixture, Uniform Motion, Constant Rate Jobs**

**1 Translate Verbal Descriptions into Mathematical Expressions**

1) A

2) A

3) A

4) A

5) A

6) A

7) A

**2 Solve Interest Problems**

1) A

2) A

3) A

4) A

5) A

6) A

**3 Solve Mixture Problems**

1) A

2) A

3) A

4) A

5) A

6) A

7) A

8) A

**4 Solve Uniform Motion Problems**

1) A

2) A

3) A

4) A

5) A

6) A

7) A

8) A

9) A

10) A

**5 Solve Constant Rate Job Problems**

1) A

2) A

3) A

4) A

5) A

## 1.7 Solving Inequalities

### 1 Use Interval Notation

1) A

2) A

3) A

4) A

5) A

6) A

7) A

8) A

9) A

10) A

11) A

12) A

13) A

14) A

15) A

16) A

### 2 Use Properties of Inequalities

1) A

2) A

3) A

4) A

5) A

6) A

7) A

8) A

### 3 Solve Linear Inequalities Algebraically and Graphically

1) A

2) A

3) A

4) A

5) A

6) A

7) A

8) A

9) A

10) A

11) A

12) A

13) A

14) A

15) A

### 4 Solve Combined Inequalities Algebraically and Graphically

1) A

2) A

3) A

4) A

5) A

6) A

7) A

- 8) A
- 9) A
- 10) A
- 11) A
- 12) A

**5 Solve Absolute Value Inequalities Algebraically and Graphically**

- 1) A
- 2) A
- 3) D
- 4) D
- 5) A
- 6) A
- 7) A
- 8) A
- 9) A
- 10) A
- 11) A
- 12) A
- 13) A
- 14) A
- 15) D
- 16) A
- 17) A